



Do 217N-1

Германский ночной истребитель II MW

Dornier Do 217 – германский многоцелевой бомбардировщик Второй мировой войны. Он был разработан в качестве замены бомбардировщика Dornier Do 17. Серийное производство длилось с ноября 1940 г. до мая 1944 г. На базе Do 217 строился Dornier Do 217N-1- ночной истребитель, с двигателями DB 603A, мощным вооружением и радаром.

Всего в 1942-1943 годах было произведено 364 ночных истребителей Дорнье 217 различных модификаций. Они состояли на вооружении нескольких ночных истребительных полков.

Тактико-технические характеристики Do 217N-1

Длина, м	17,67
Размах крыла, м.....	19,0
Взлетный вес, кг	13200
Двигатель	2хDB 603A, 1850 л.с.
Максимальная скорость, км/ч.....	515
Потолок, м.....	8900
Дальность, км.....	1755
Вооружение	4х20-мм пушки MG FF, 4х7,92-мм пулемета MG 17, 2х13,2-мм пулемета MG 131

ВНИМАНИЕ!

Перед сборкой внимательно прочитать руководство по монтажу. Каждая деталь пронумерована. Соблюдать последовательность монтажа. Необходимые рабочие инструменты: нож и напильник для зачистки деталей; резиновая лента, клейкая лента и зажимы для сушки белья для прижимания склеиваемых деталей. Детали из пластика очистить в растворе мягкого моющего средства и высушить на воздухе для того, чтобы краска и переводные картинки лучше прилипали. Перед приклеиванием проверить, подходят ли детали; клей наносить экономно. Хром и краску удалить с поверхностей склеивания. Небольшие детали покрасить перед тем, как они будут удалены из рамок. Краску необходимо хорошо просушить, только после этого продолжать сборку. Каждую соответствующую переводную картинку отдельно вырезать и примерно на 20 секунд окунуть в теплую воду. На обозначенном месте картинку отделить от бумаги и прижать промокательной бумагой.

Do 217N-1

WWII German Night Fighter

Dornier Do 217 was a German multi-purpose bomber of the Second World War. It was developed as a replacement for the Dornier Do 17 bomber. It was produced serially from November 1940 to May 1944. Dornier Do 217N-1 was night fighter on Do 217 base, with DB 603A engines, powerful armament and radar.

In total, in 1942-1943, it were produced 364 Dornier 217 night fighters of different modifications. They were in service with several night fighter regiments.

Tactical and Technical Specifications of Do 217N-1

Length, m	17,67
Span, m	19,0
Start Weight, kg.....	13200
Engine.....	2хDB 603A, 1850 hp.
Max. Speed, km/h.....	515
Service ceiling, m.....	8900
Range, km	1755
Armament...4х20-mm MG FF, 4х7,92 mm MG 17, 2х13,2 mm MG 131	

CAUTION!

Read the instructions thoroughly prior to assembly. Each component is numbered. Adhere to specified sequence of assembly. Tools required: knife and file for removal of components from frame; rubber bond, adhesive tape and clothes pegs for clamping components together after applying adhesive. Clean plastic components in a mild detergent solution and allow to air-dry so that paint and transfers adhere better. Prior to applying adhesive, check to see whether the components fit together; apply adhesive sparingly. Remove chrome and paint from the contact surfaces. Paint small components before removing them from the frame. Allow paint to dry well, and only then continue to assemble. Cut out each transfer individually and immerse in warm water for approx. 20 seconds. Slide transfer off paper and into designated position, then press on with blotting paper.

ИСПОЛЬЗУЕМЫЕ КРАСКИ / USED COLORS:

	Revell	Tamiya		
A	108	XF1	Черный, матовый	Flat Black
B	105	XF2	Белый, матовый	Flat White
C	167	XF51	Темный серо-зеленый, мат.	Dunkelgrau RLM 74
D	140	XF27	Черно-зеленый RLM 70	Schwarzgrun RLM70
E	179	XF25	Серо-голубой, матовый	Mittelgrau RLM 75
F	149	XF19	Светлый серо-голубой, мат.	Hellblau RLM 76

	Revell	Tamiya		
G	177	XF84	Черно-серый, матовый	Schwarzgrau RLM66
H	145	XF22	Серо-зеленый RLM02	Grau RLM02
J	199	XF16	Алюминий, полуматовый	Aluminium
K	191	X11	Сталь	Steel
L	109	X10	Темный металл	Gun Metal
M	183	XF64	Ржавчина	Rust
N	731	X27	Красный, прозрачный	Clear Red
P	161	X25	Зеленый, прозрачный	Clear Green

01 СТАДИЯ СБОРКИ
ASSEMBLY STEP

✂ ОТРЕЗАТЬ
CUT OFF

***** СДЕЛАТЬ САМОМУ
SCRATCH BUILD

x2 СДЕЛАТЬ ДВЕ ДЕТАЛИ
MAKE 2 PCS

03 СБОРОЧНАЯ ЕДИНИЦА
ASSEMBLY UNIT

A ИСПОЛЬЗУЕМАЯ КРАСКА
USED COLOR

? ПРОИЗВОЛЬНЫЙ ВЫБОР
OPTIONAL

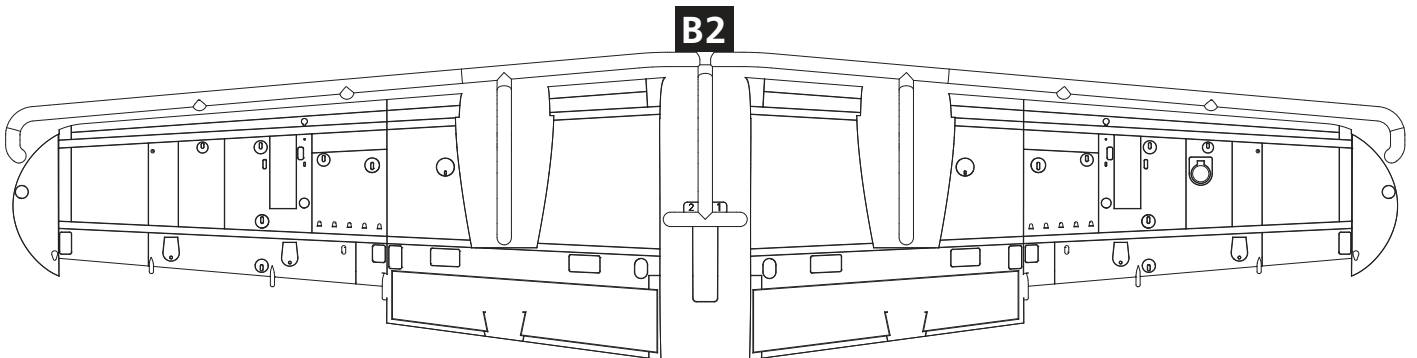
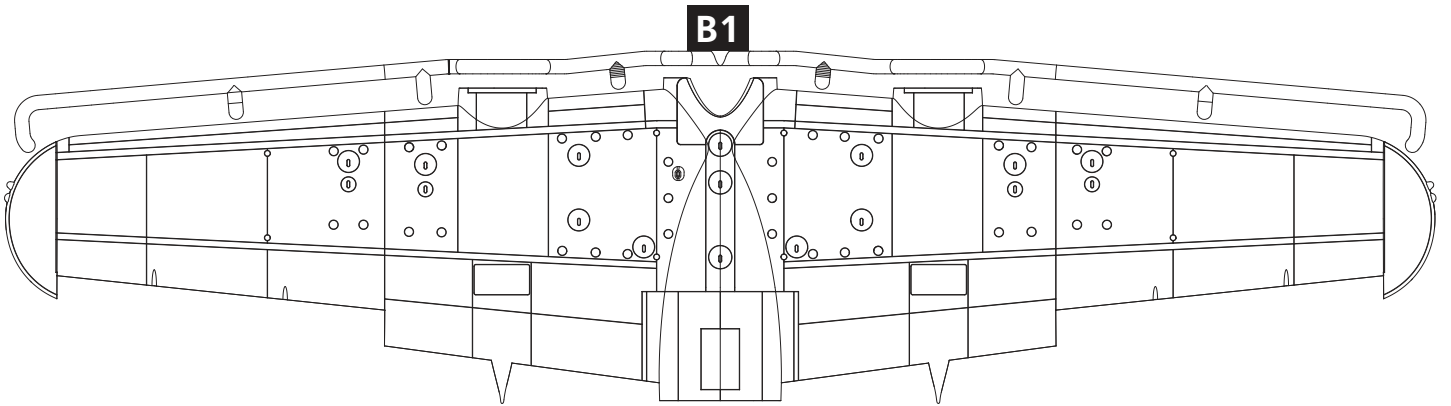
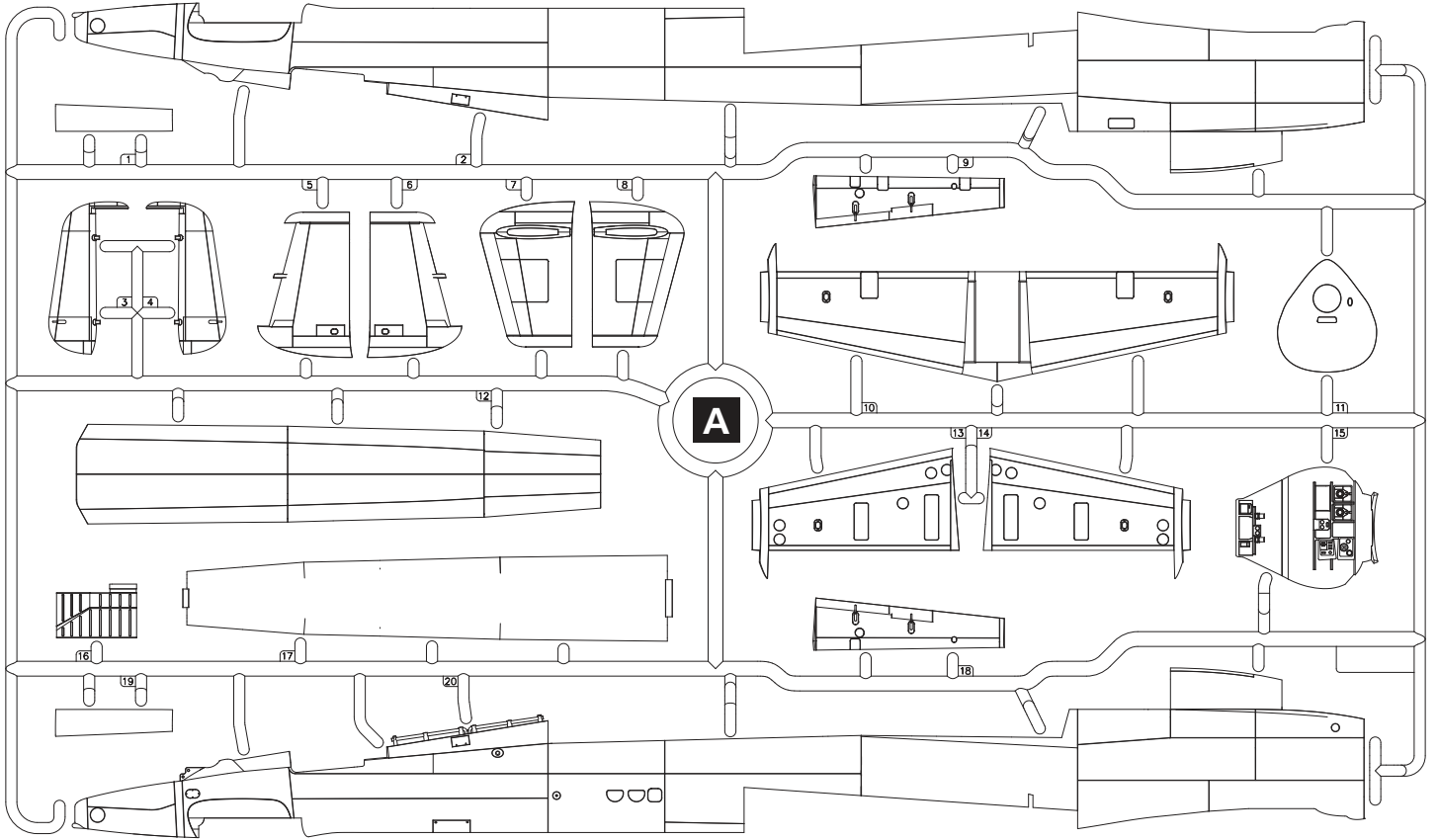

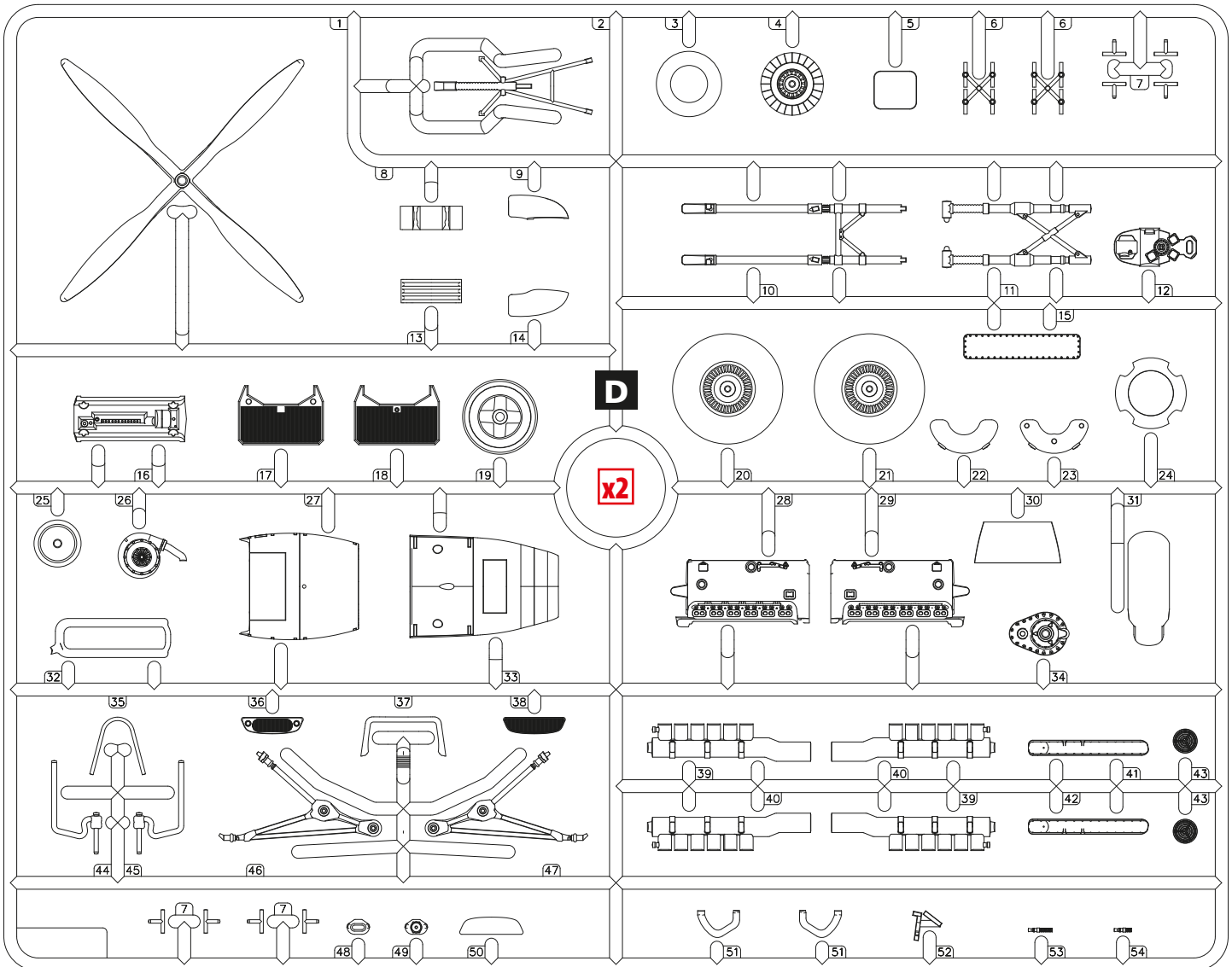
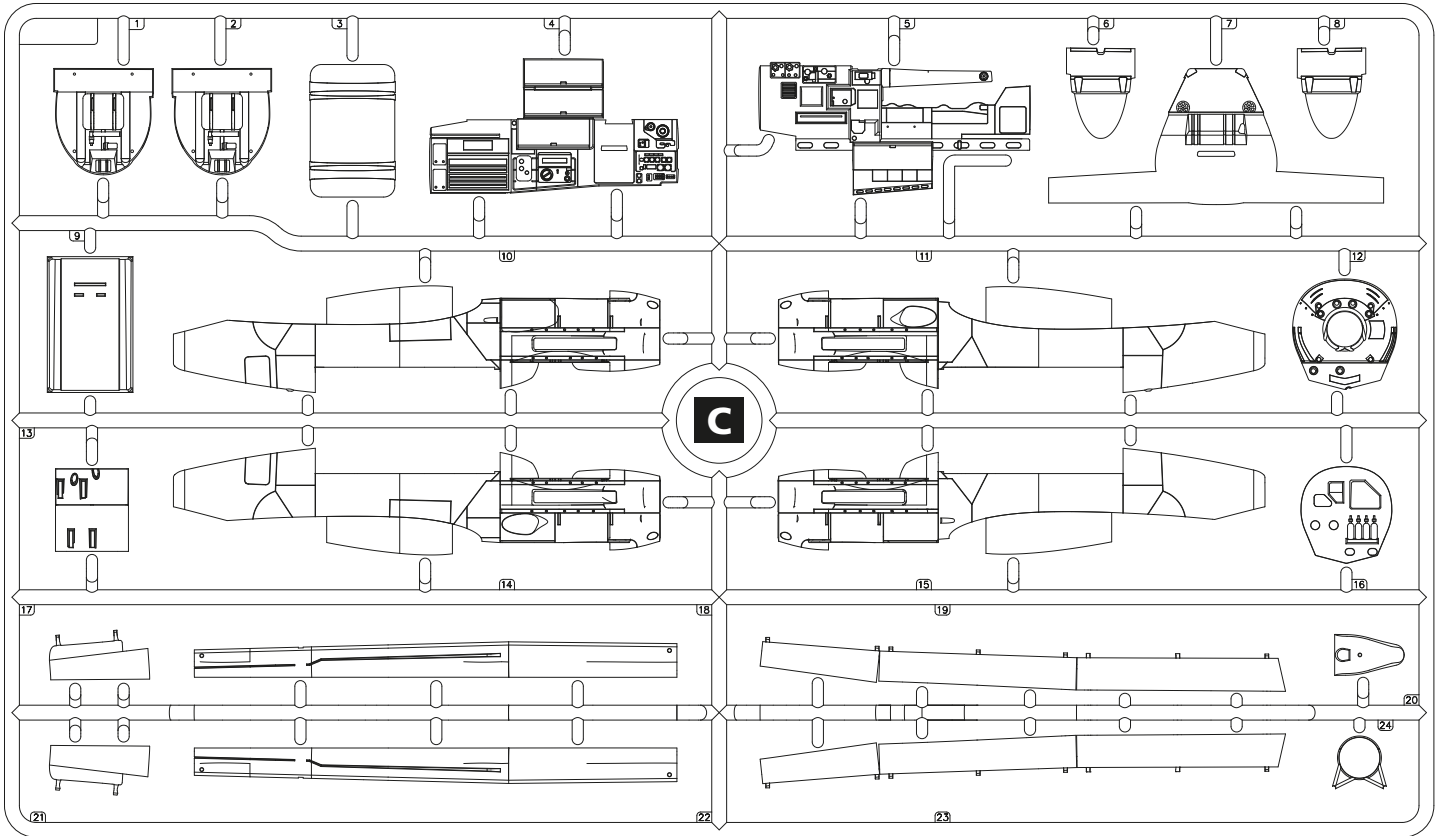

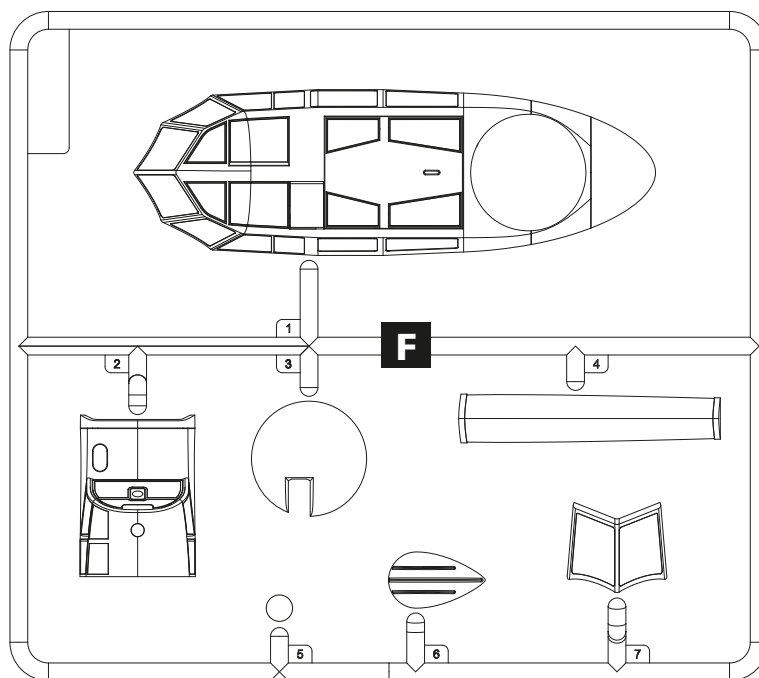
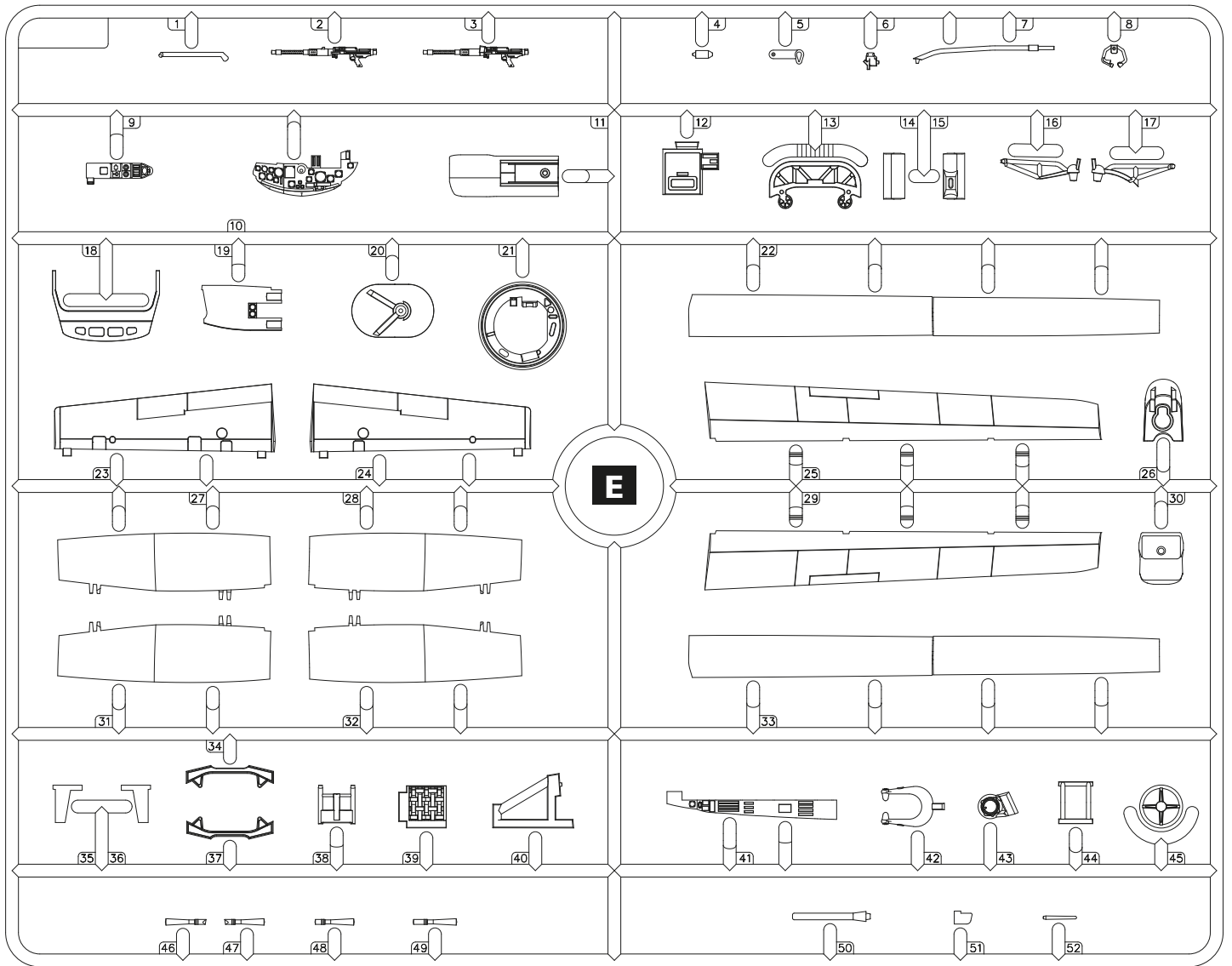

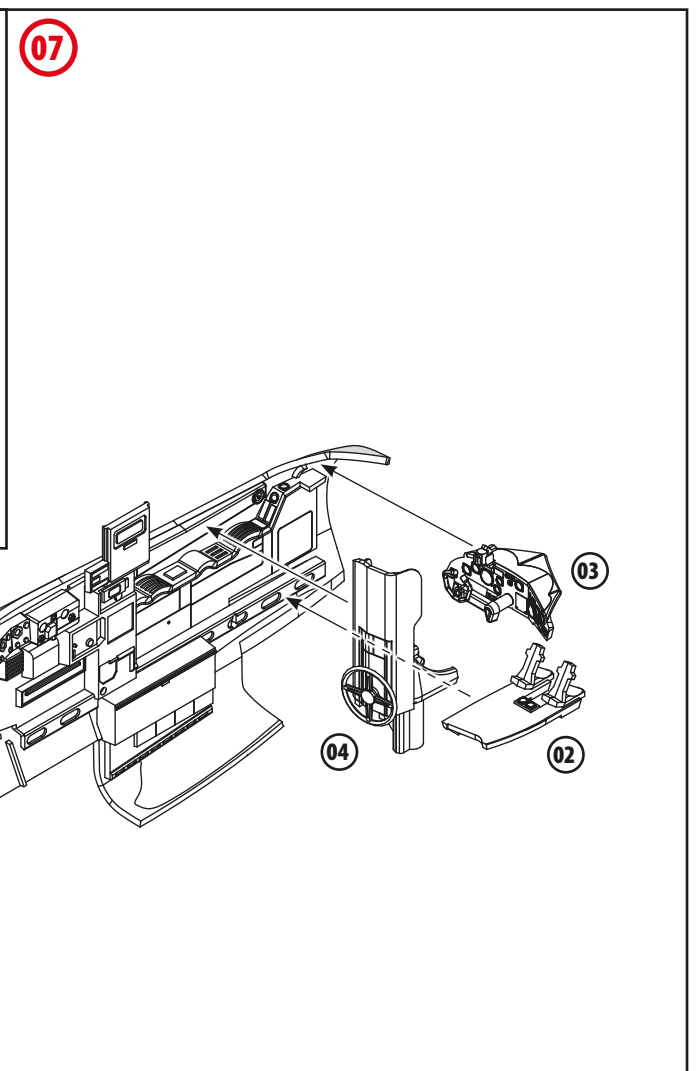
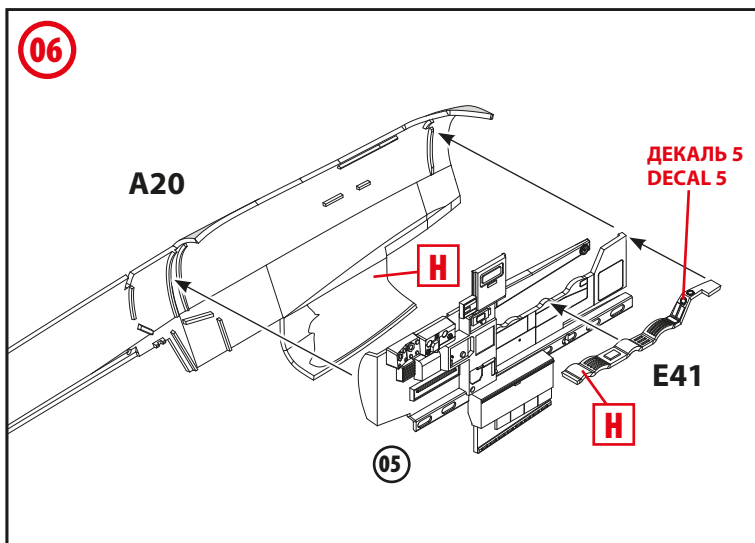
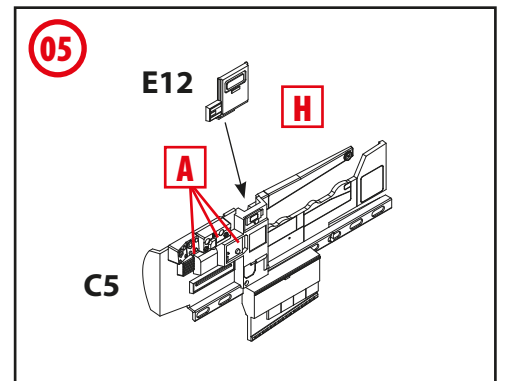
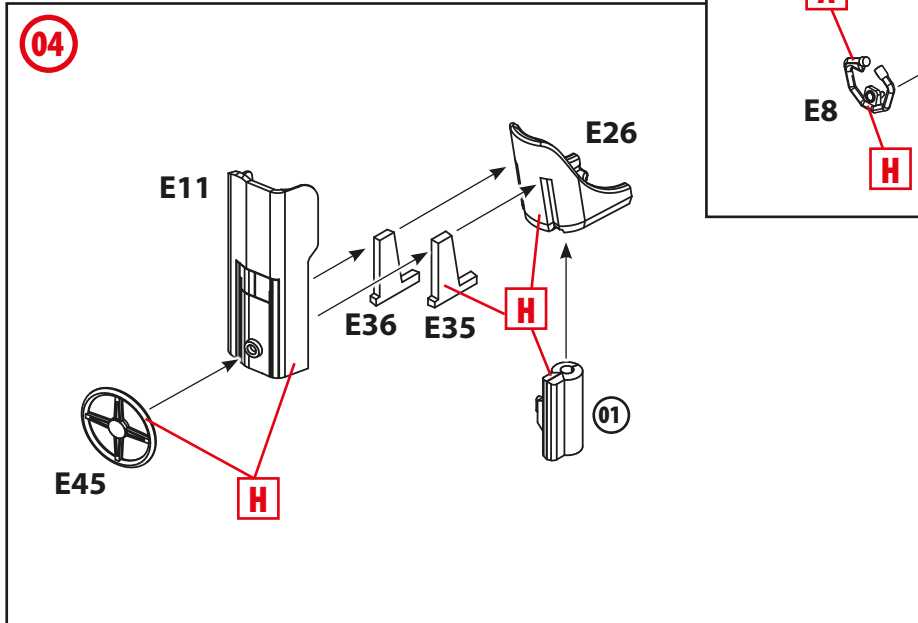
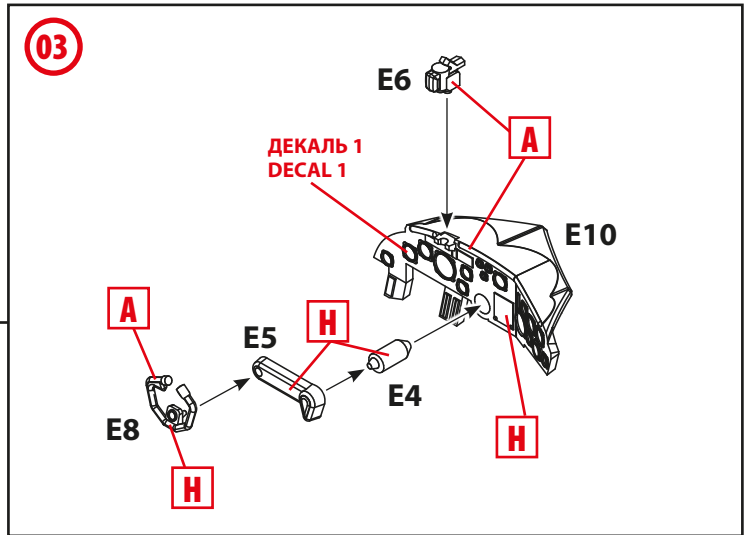
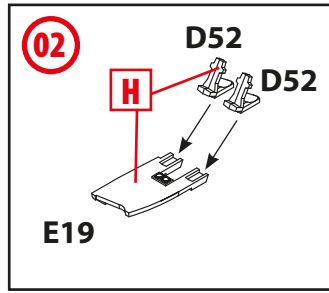
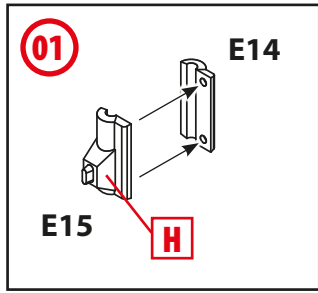

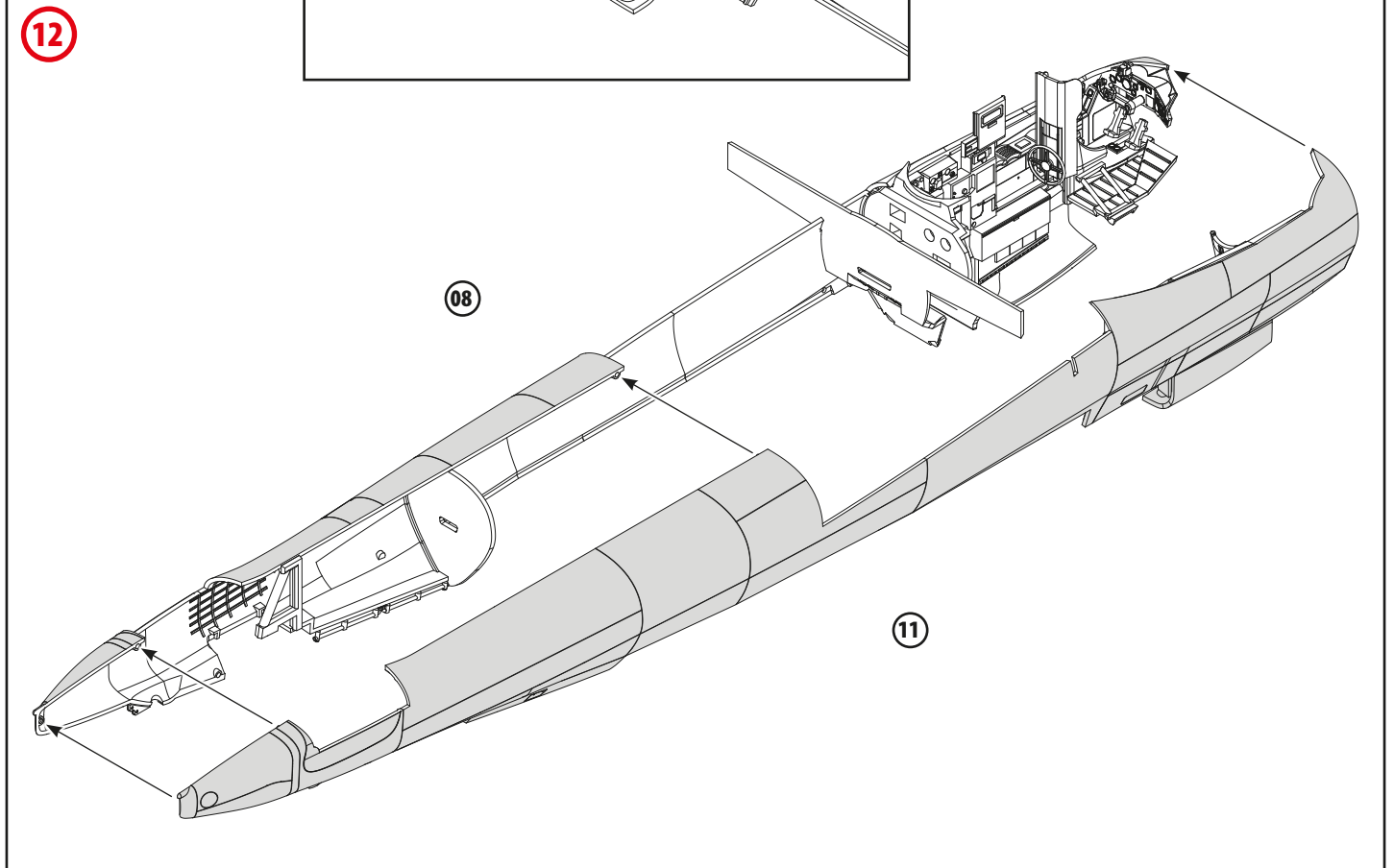
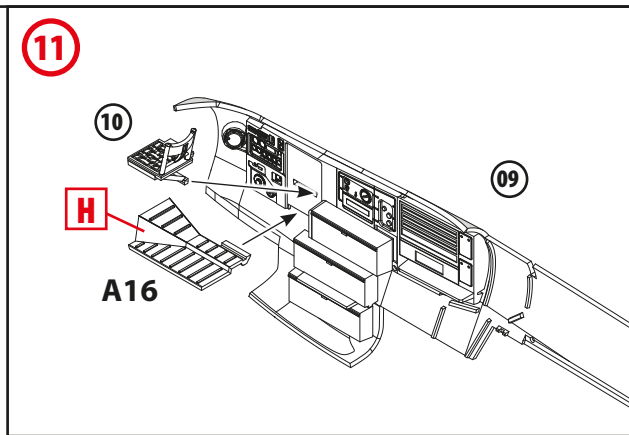
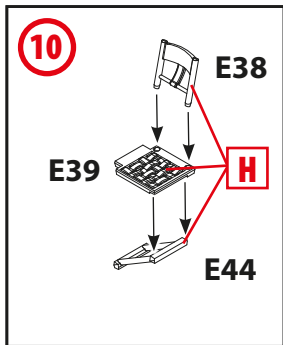
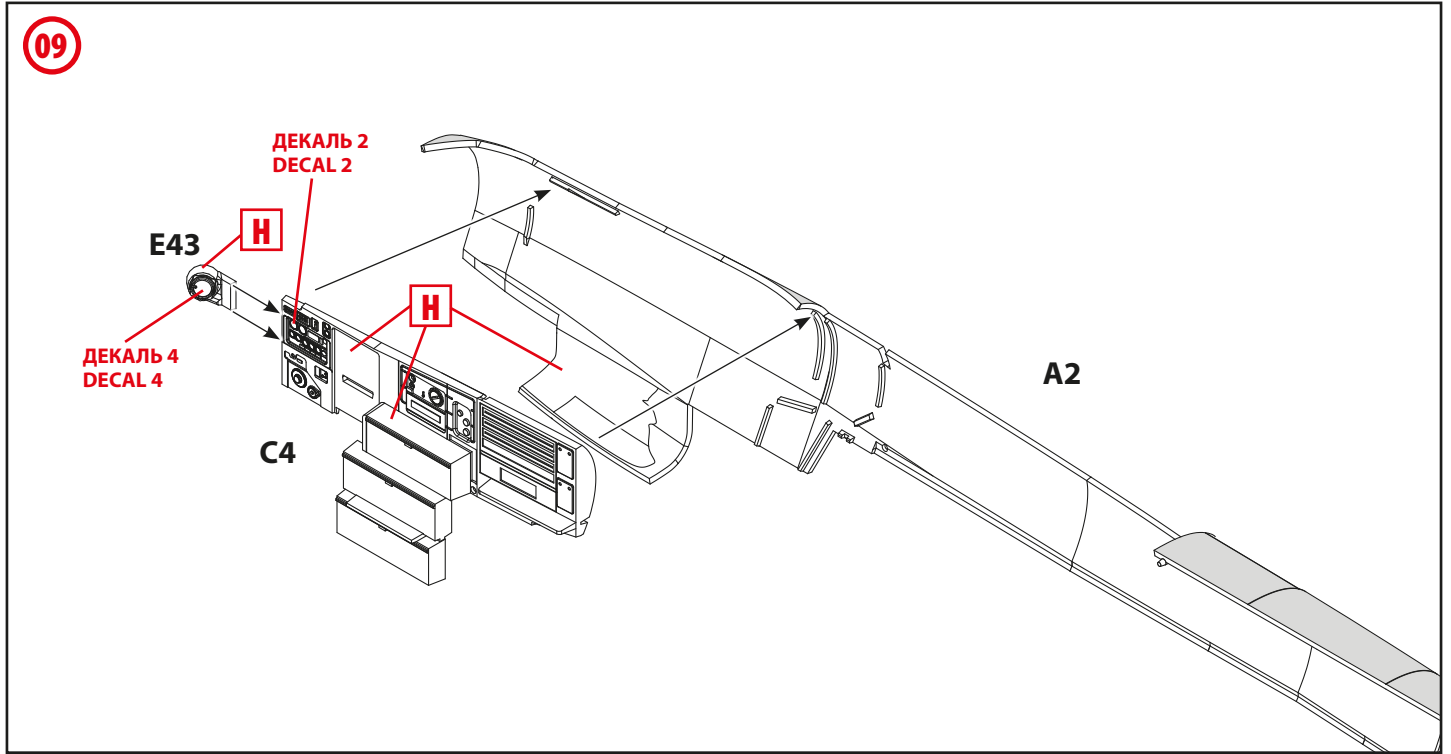

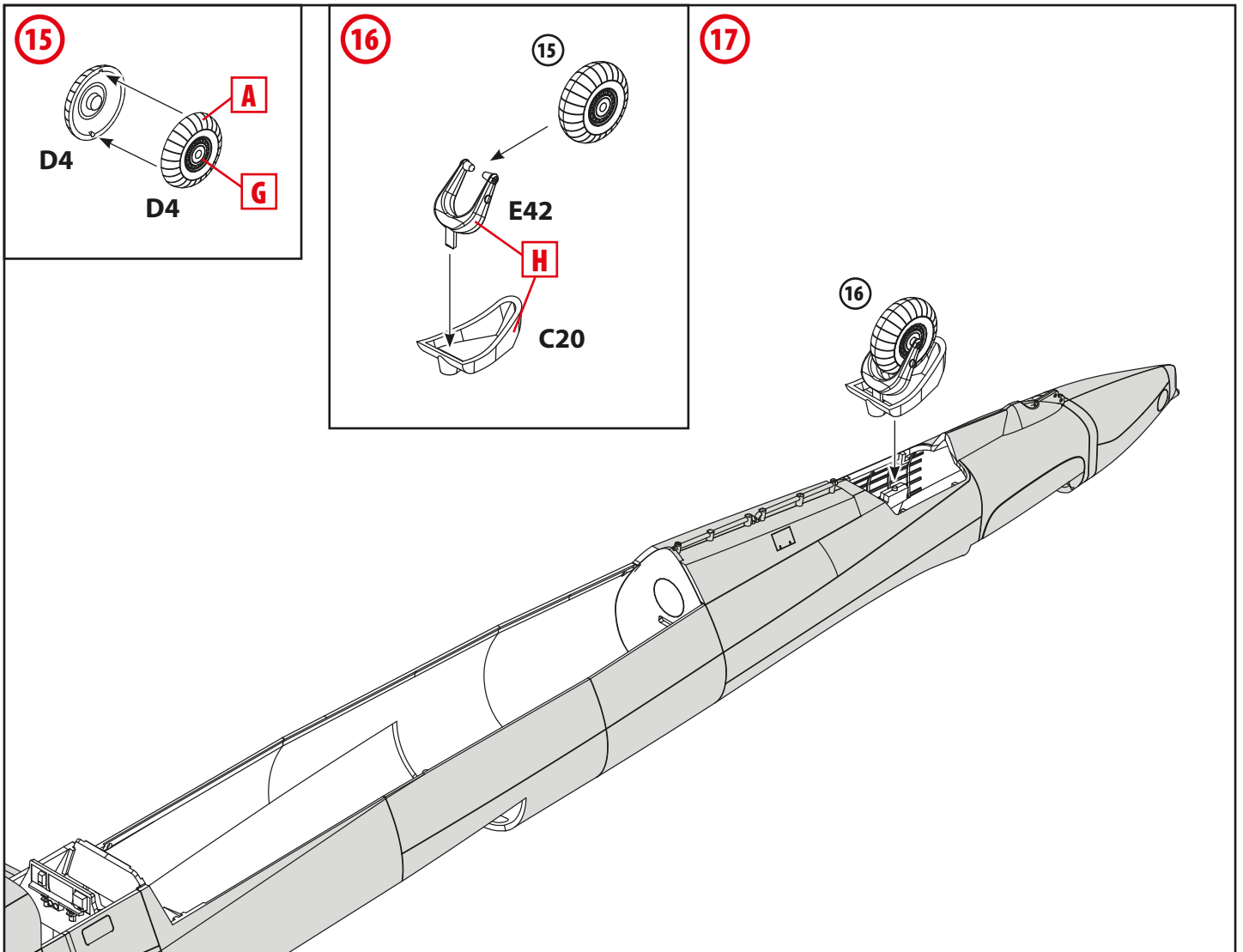
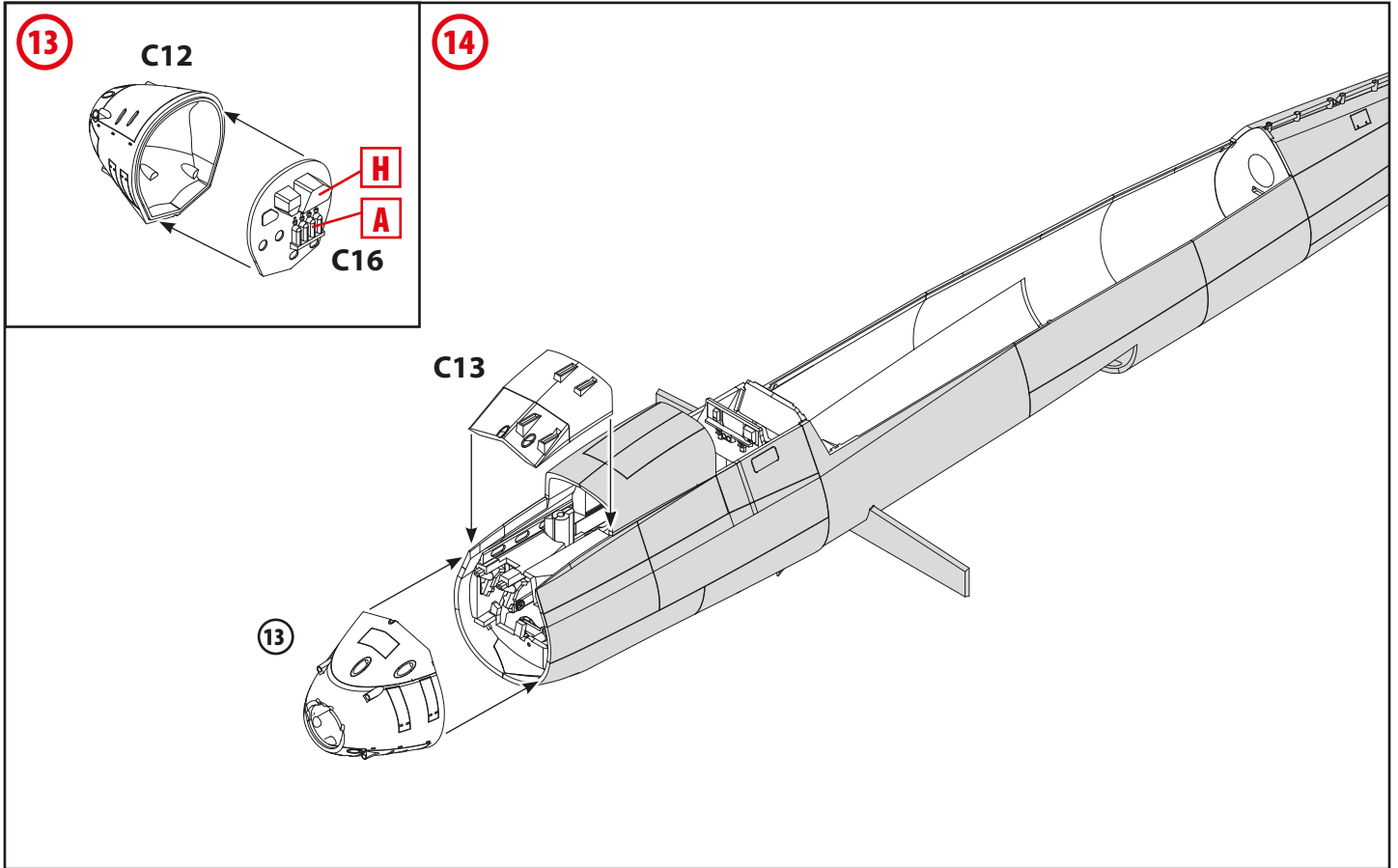

18

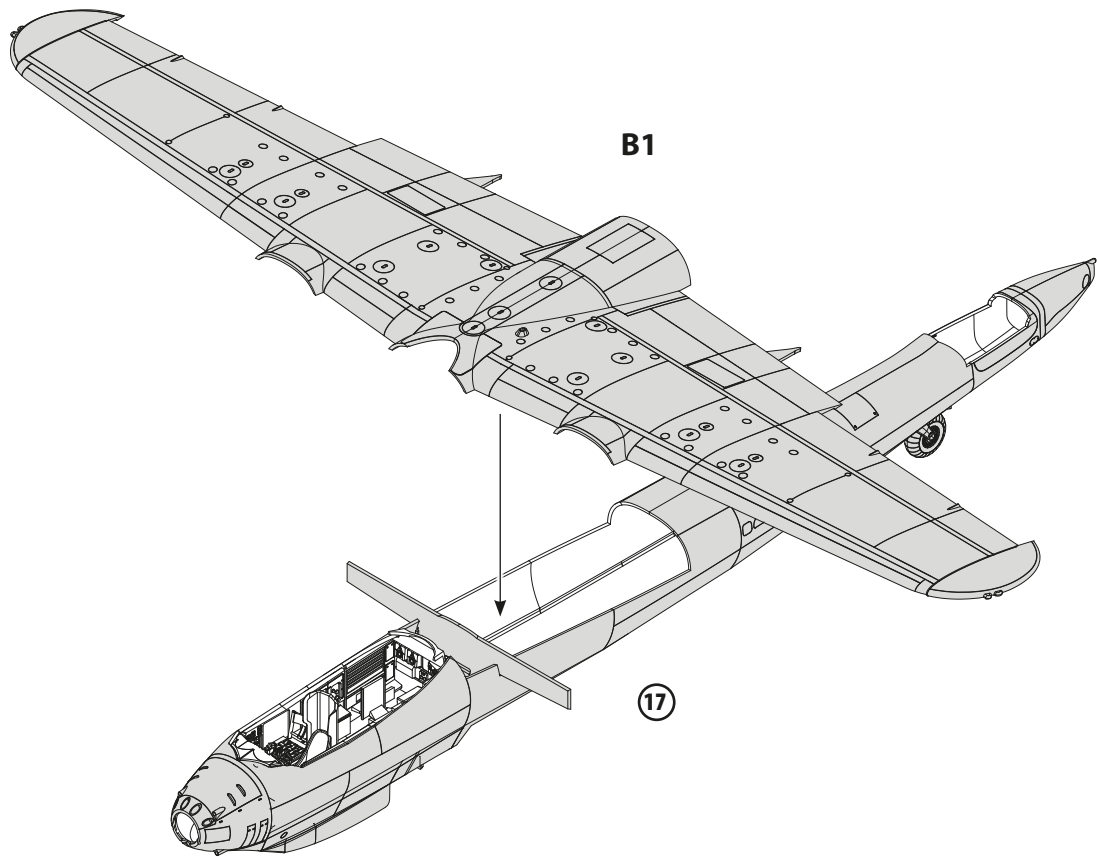

19

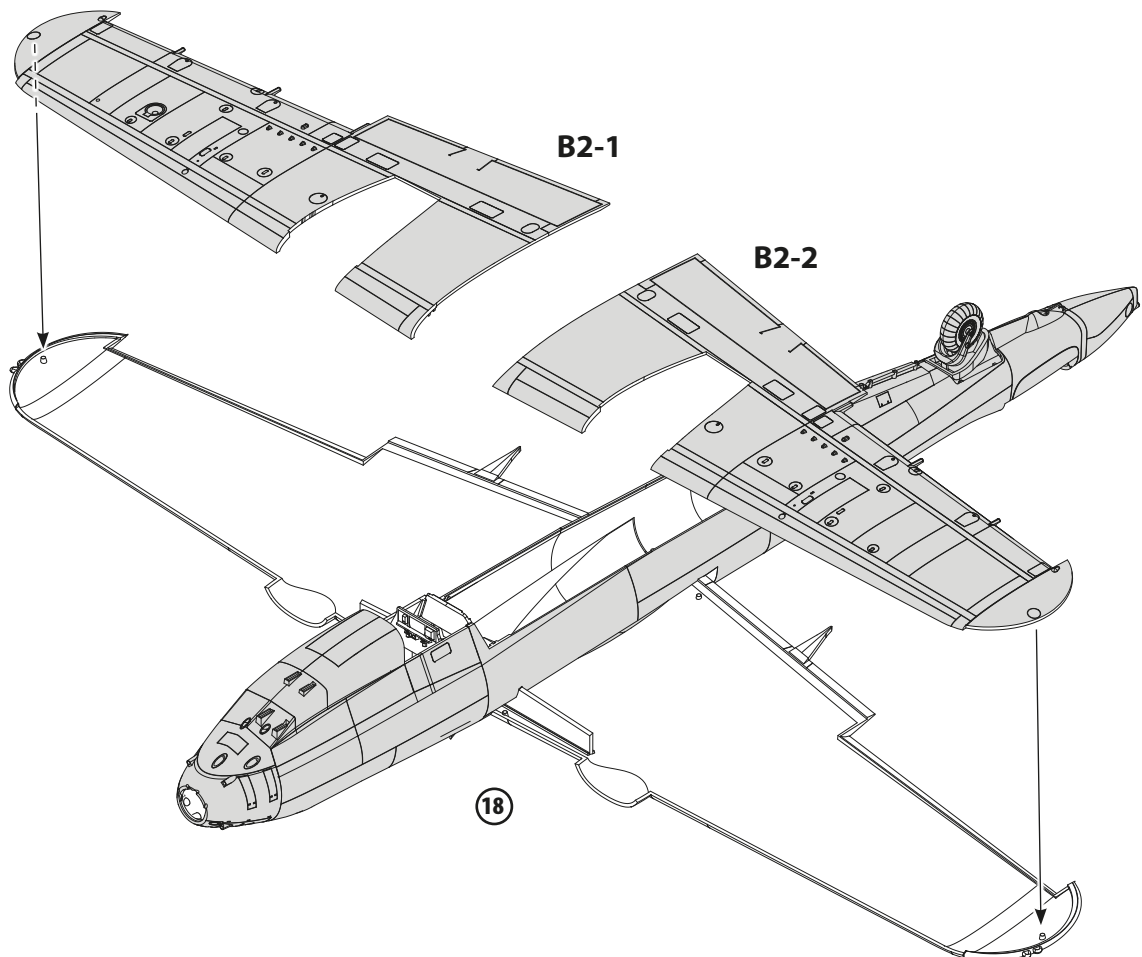

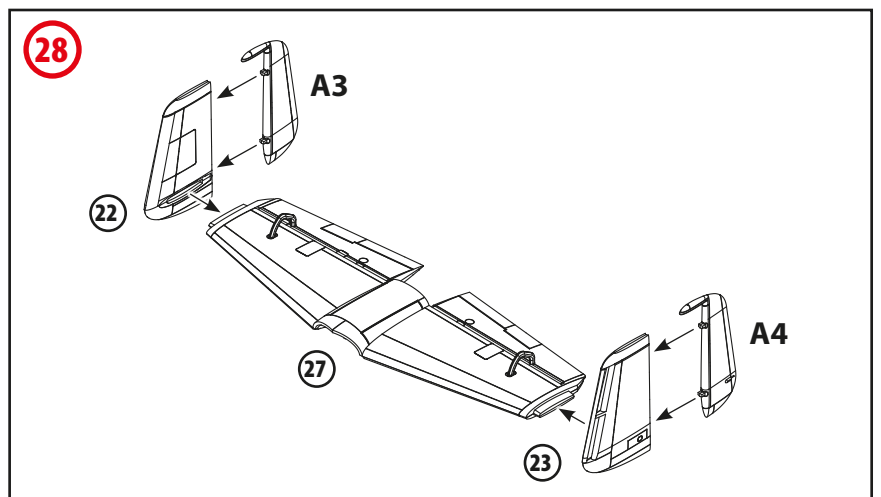
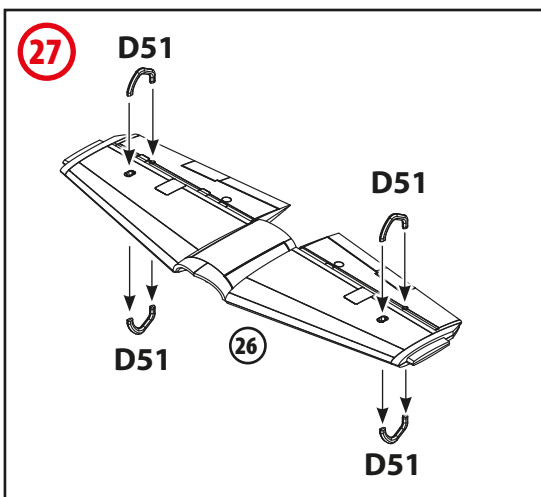
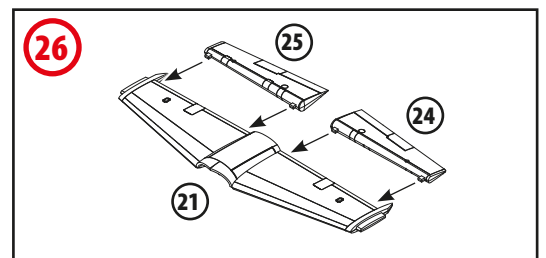
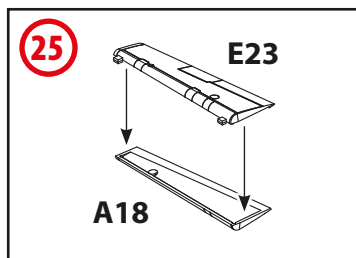
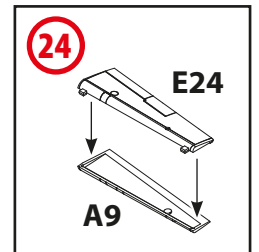
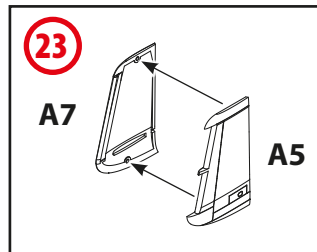
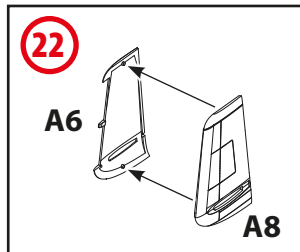
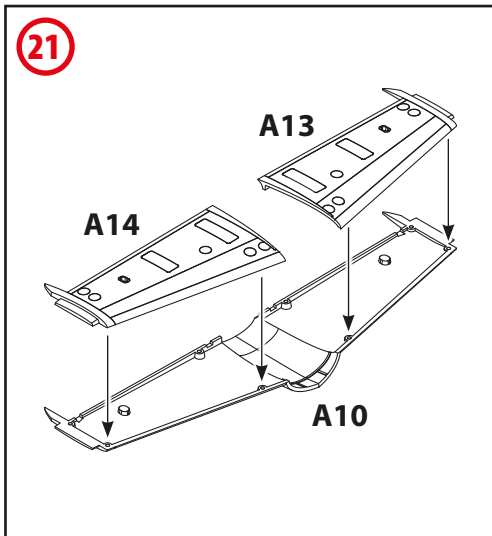
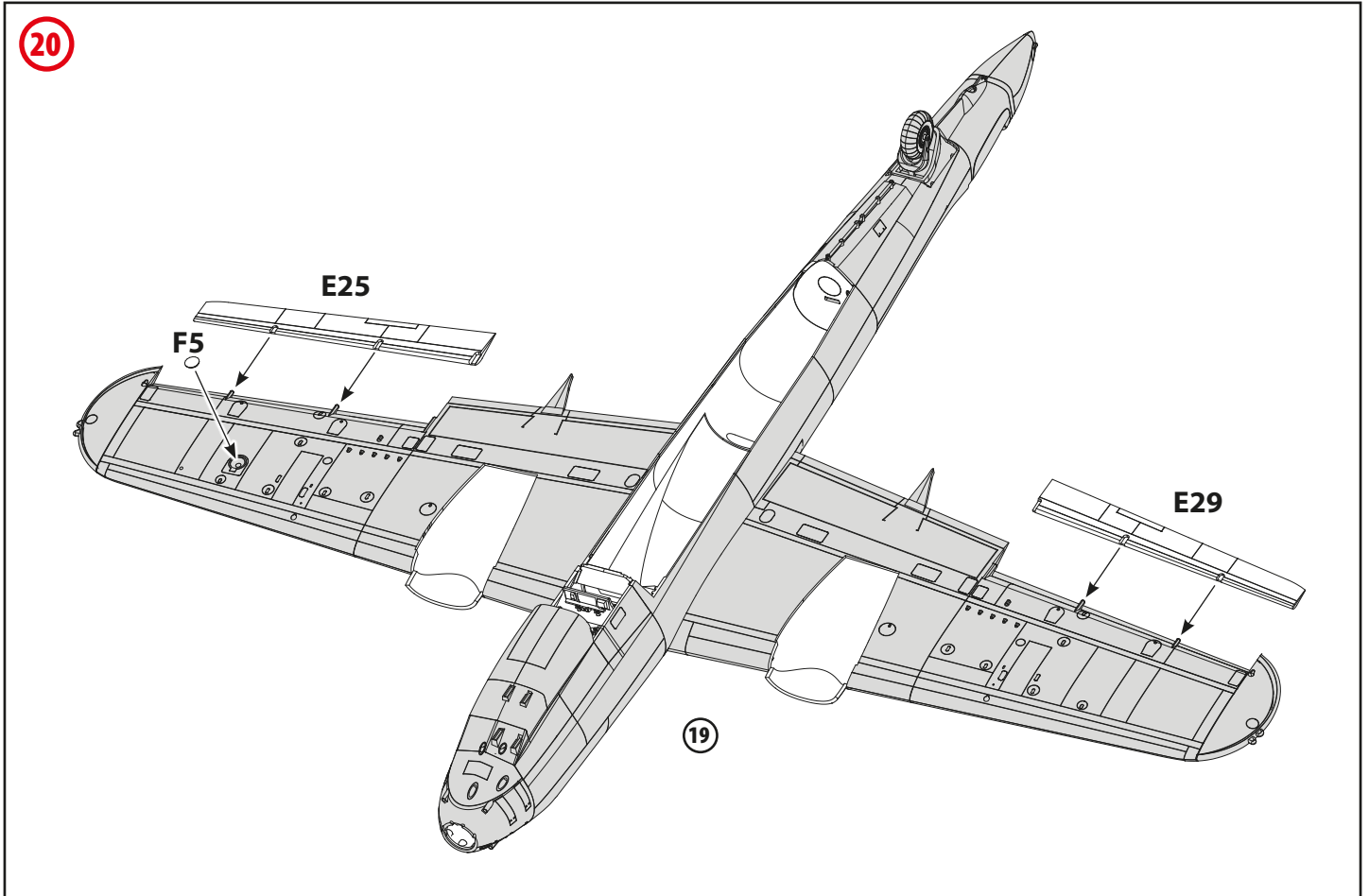

29

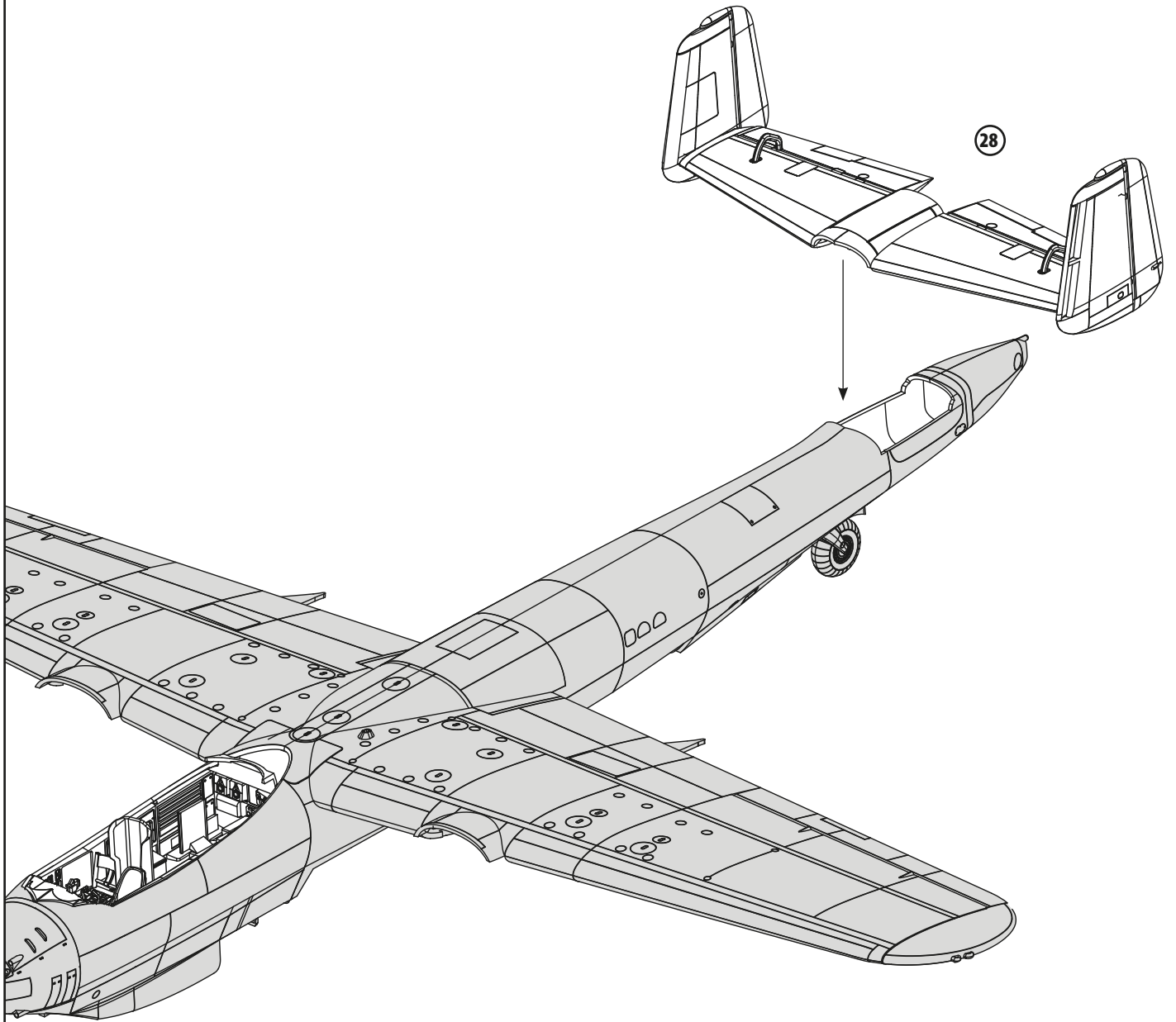

30

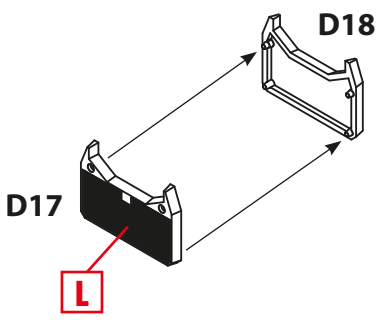

31

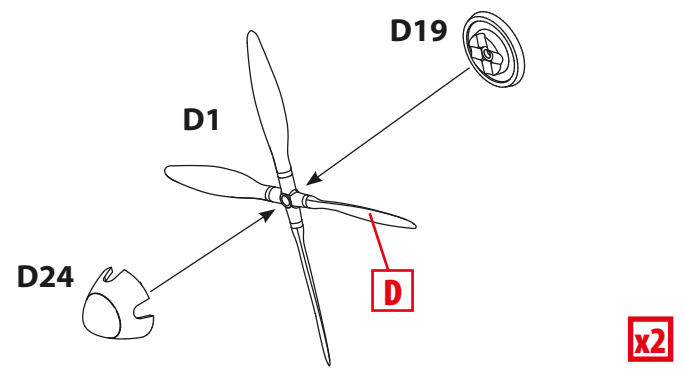

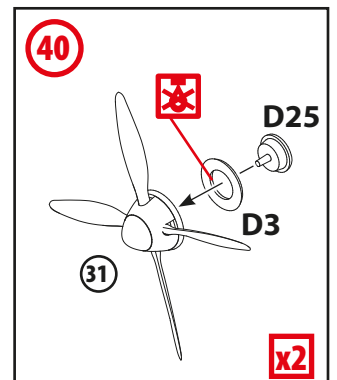
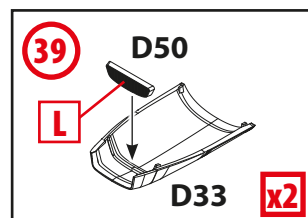
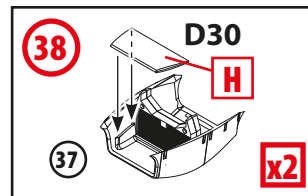
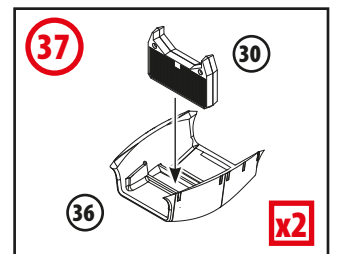
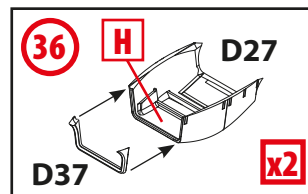
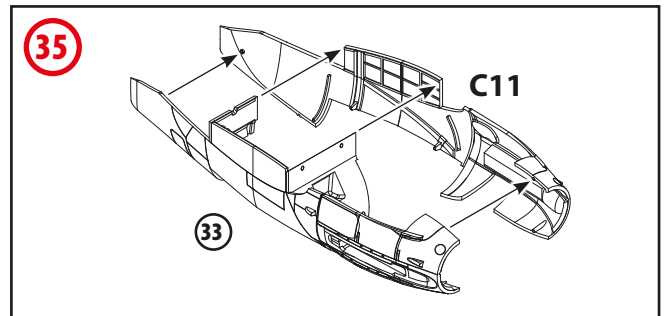
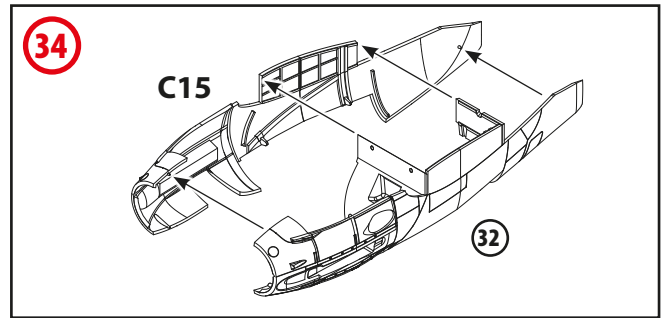
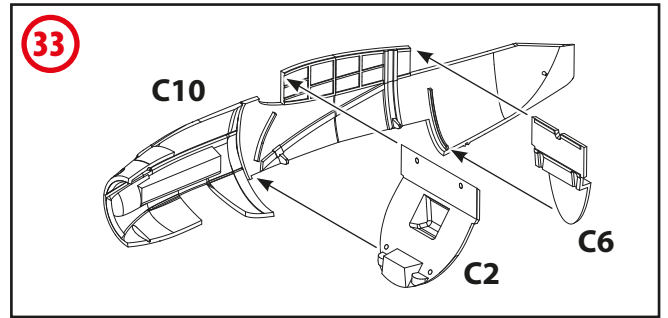
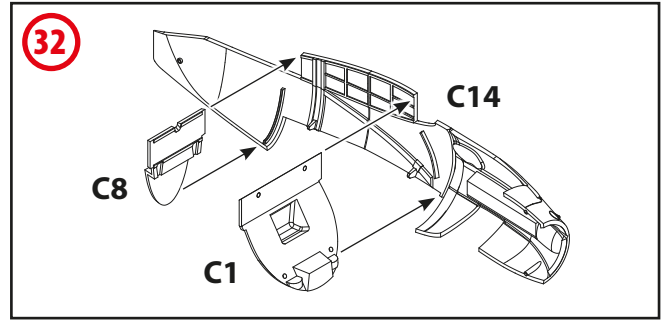
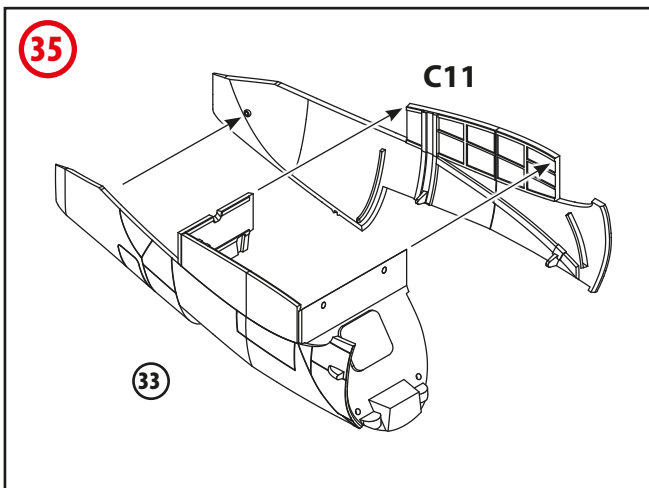
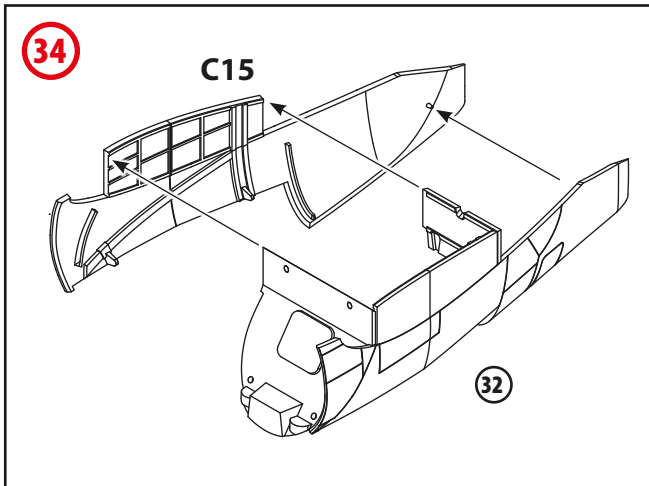
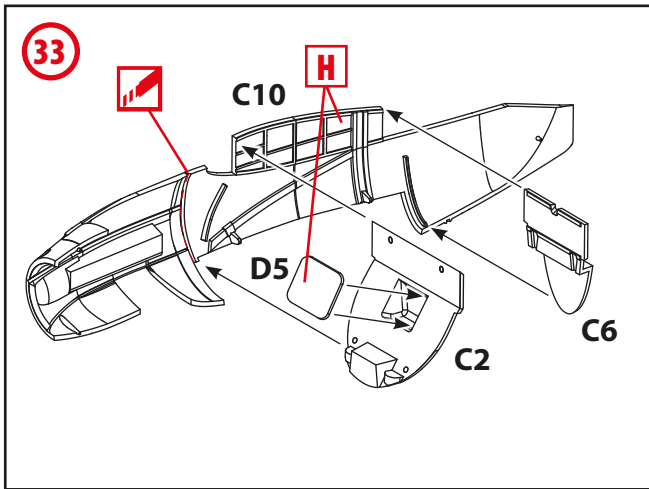
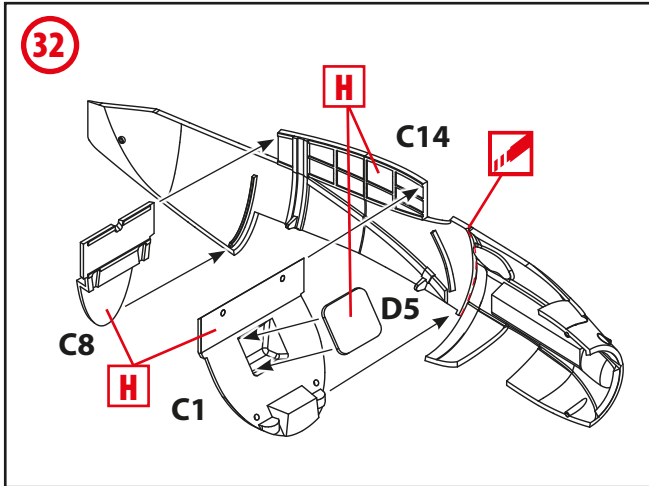

?

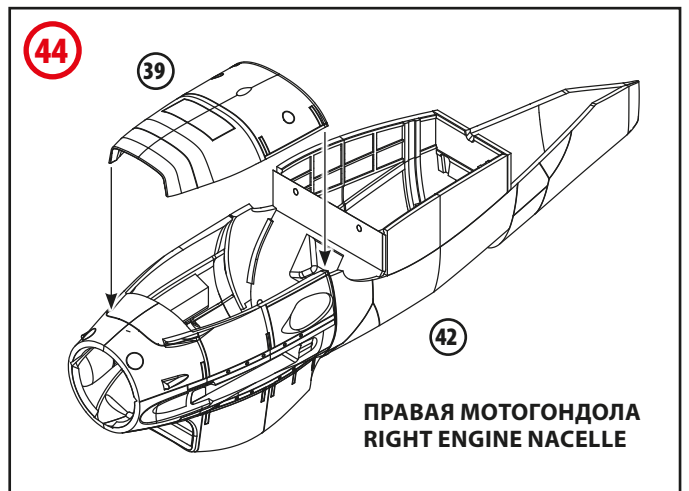
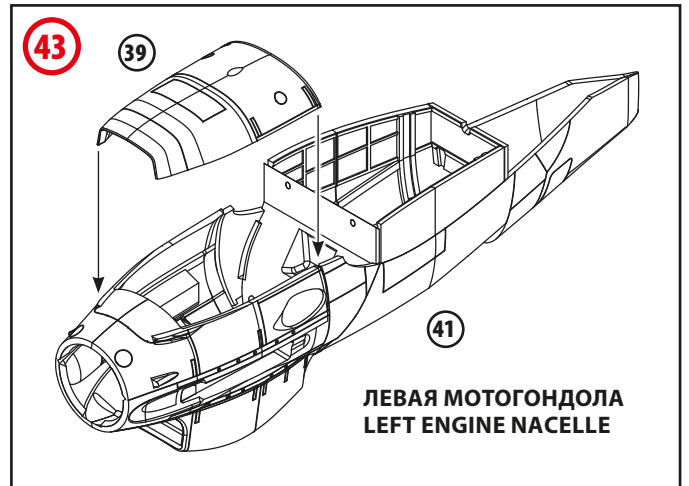
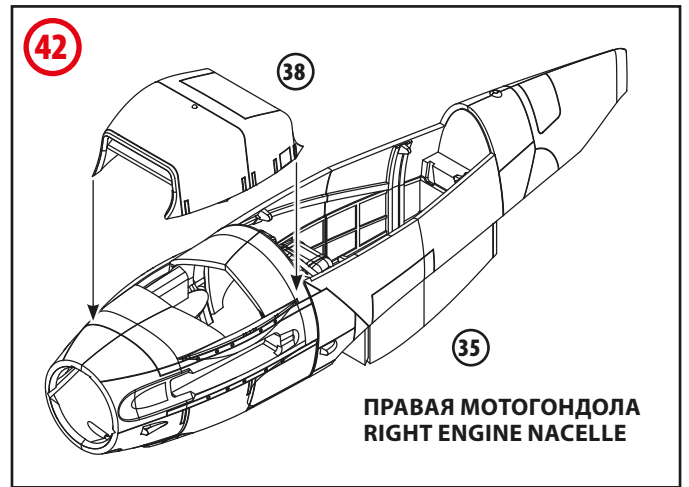
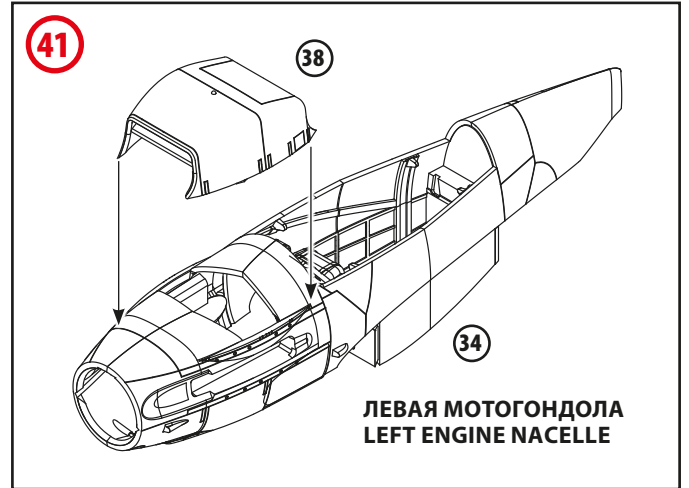
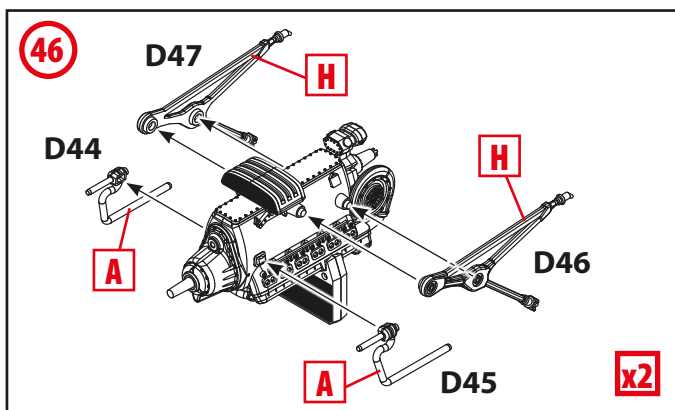
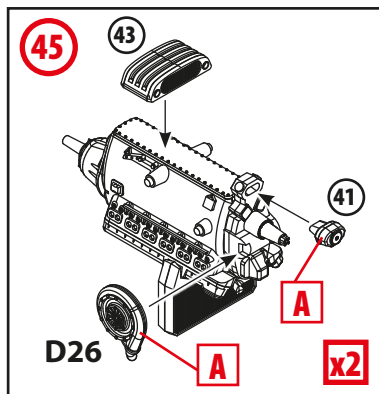
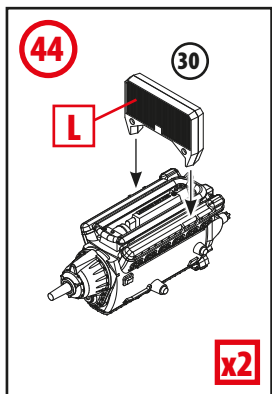
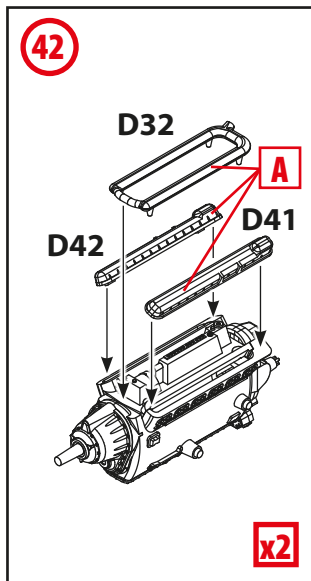
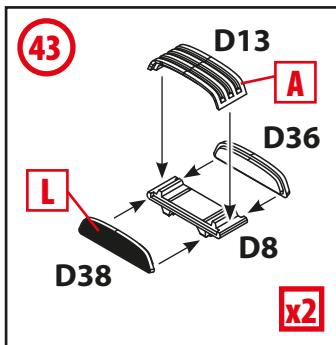
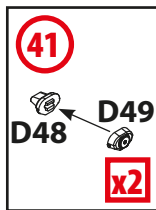
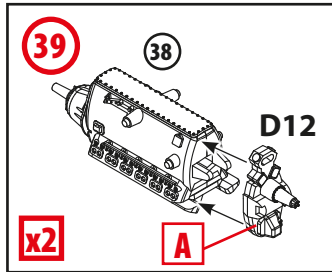
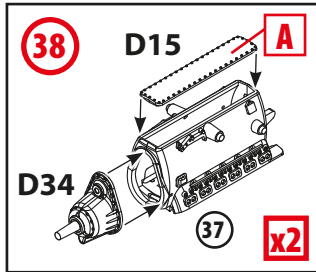
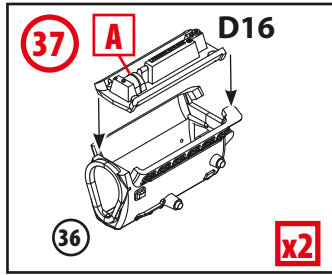
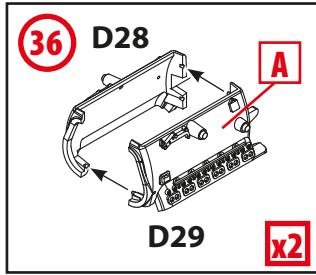

?

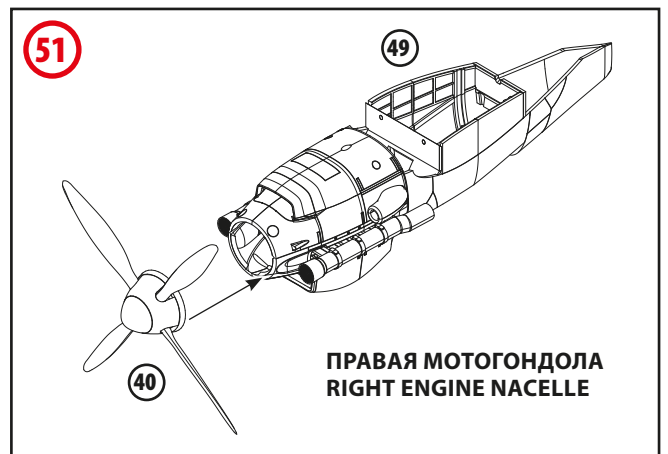
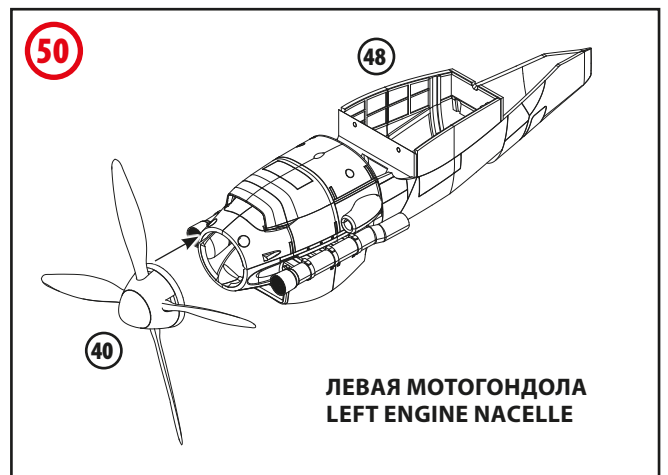
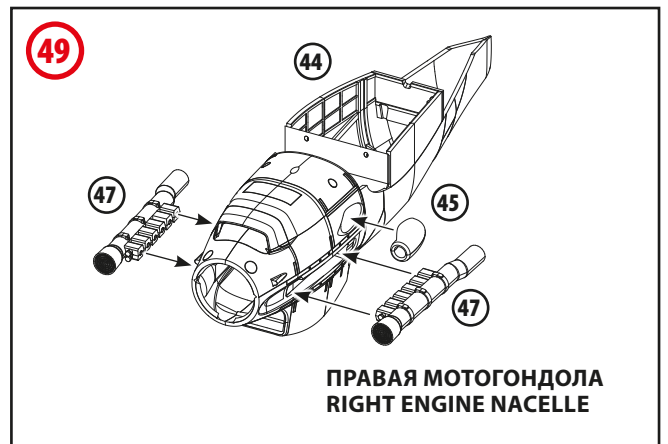
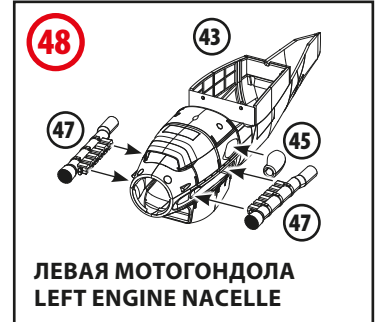
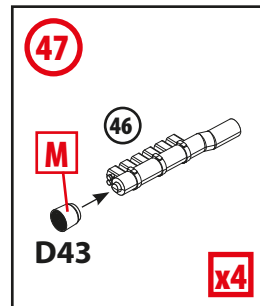
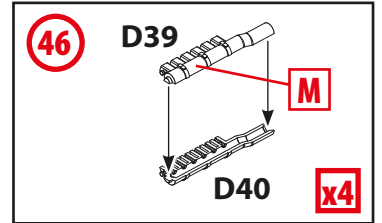
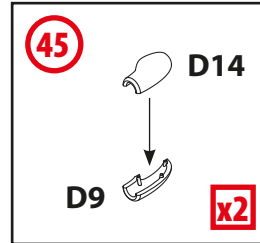
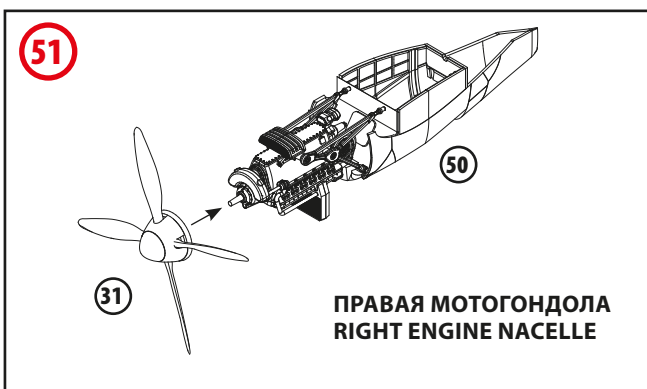
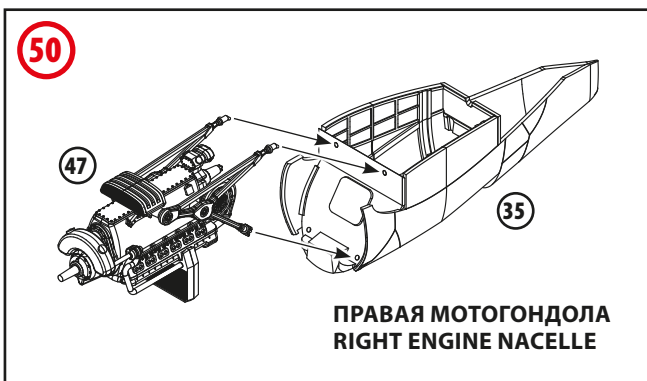
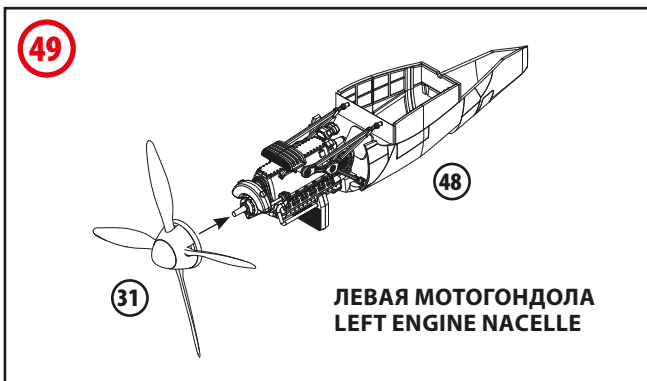
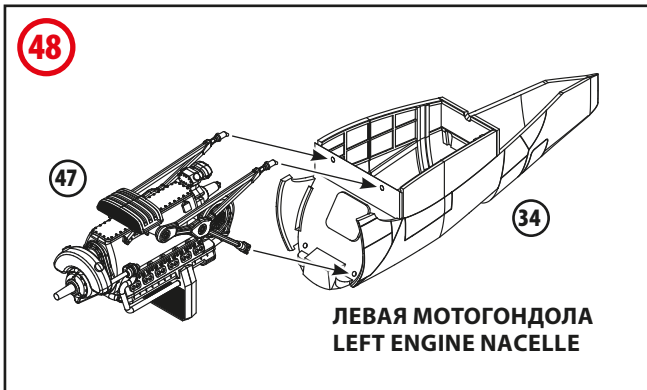
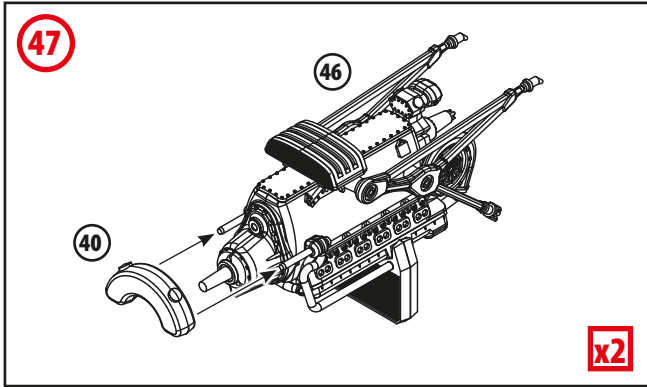

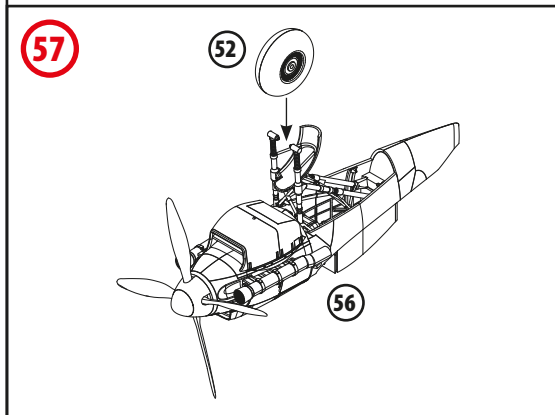
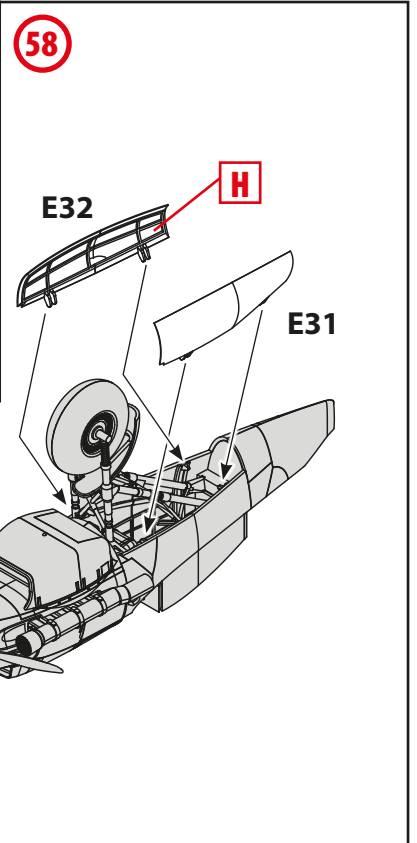
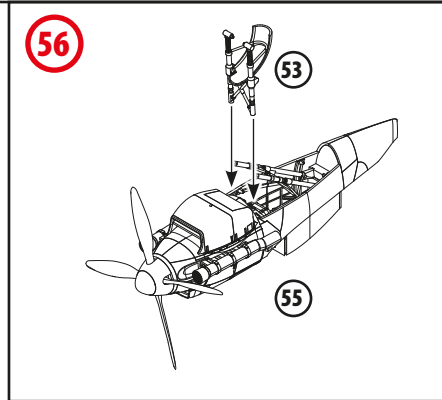
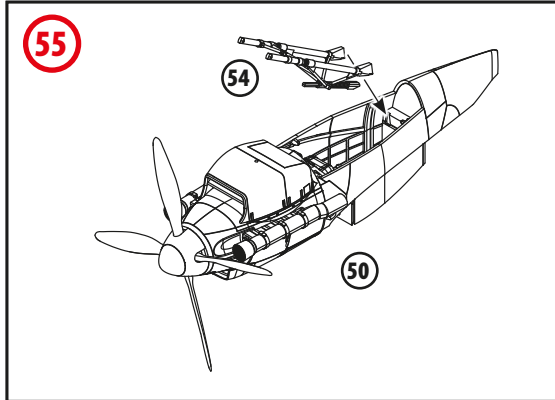
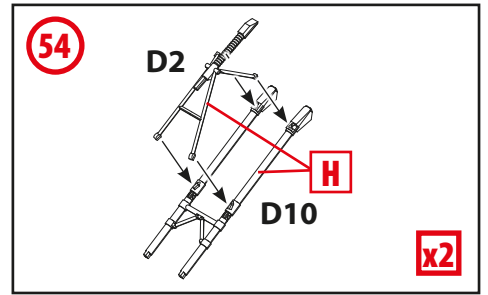
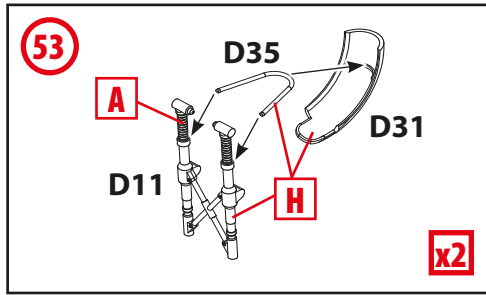
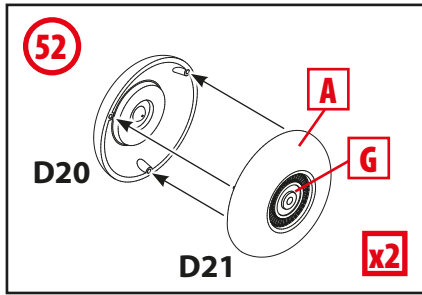

ЛЕВАЯ МОТОГОНДОЛА
LEFT ENGINE NACELLE

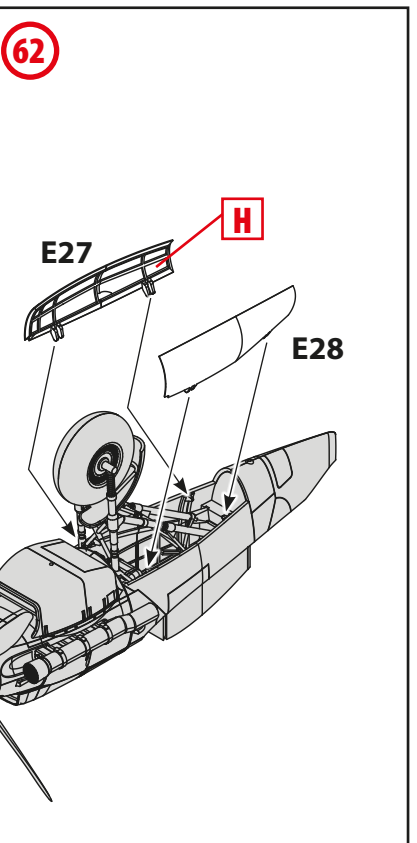
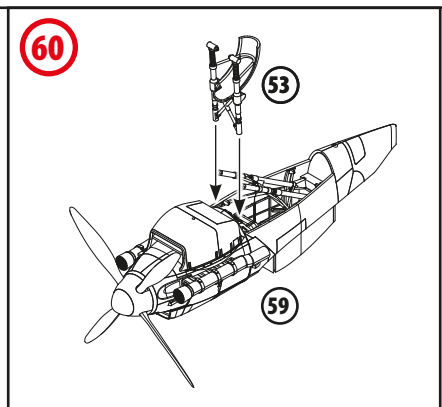
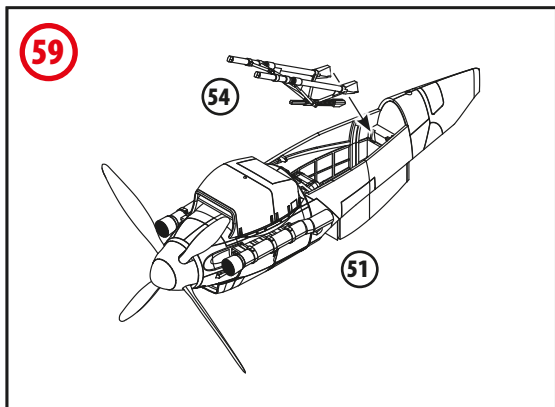

ПРАВАЯ МОТОГОНДОЛА
RIGHT ENGINE NACELLE

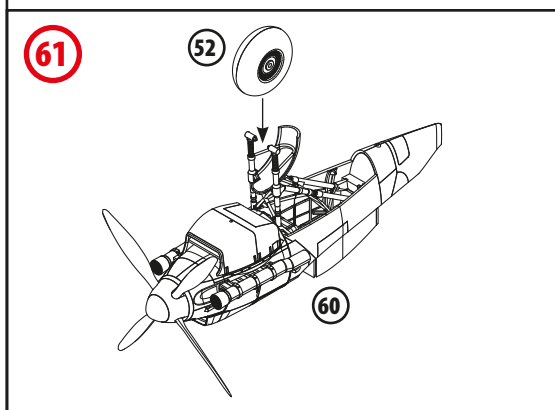

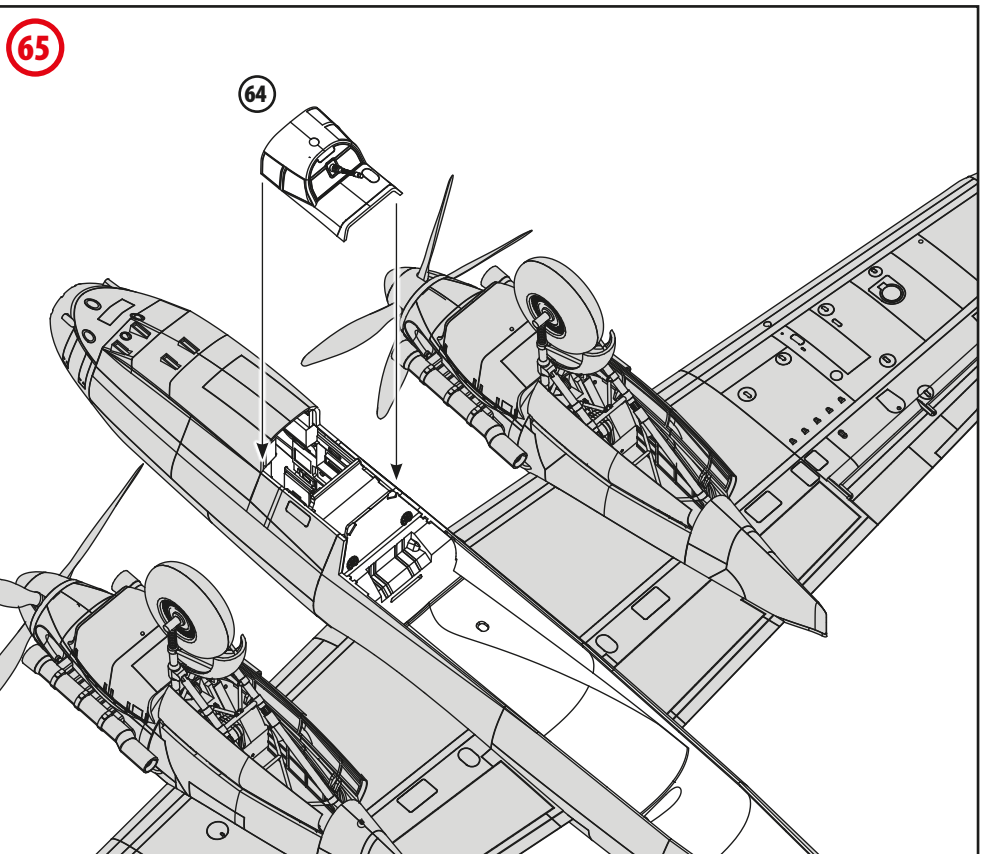
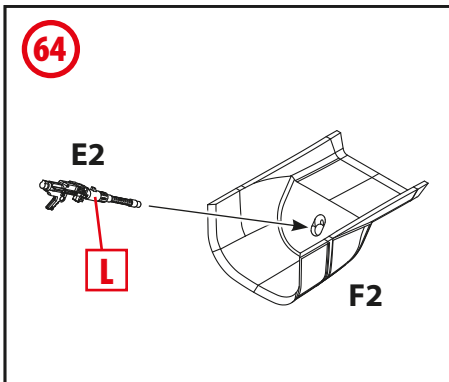
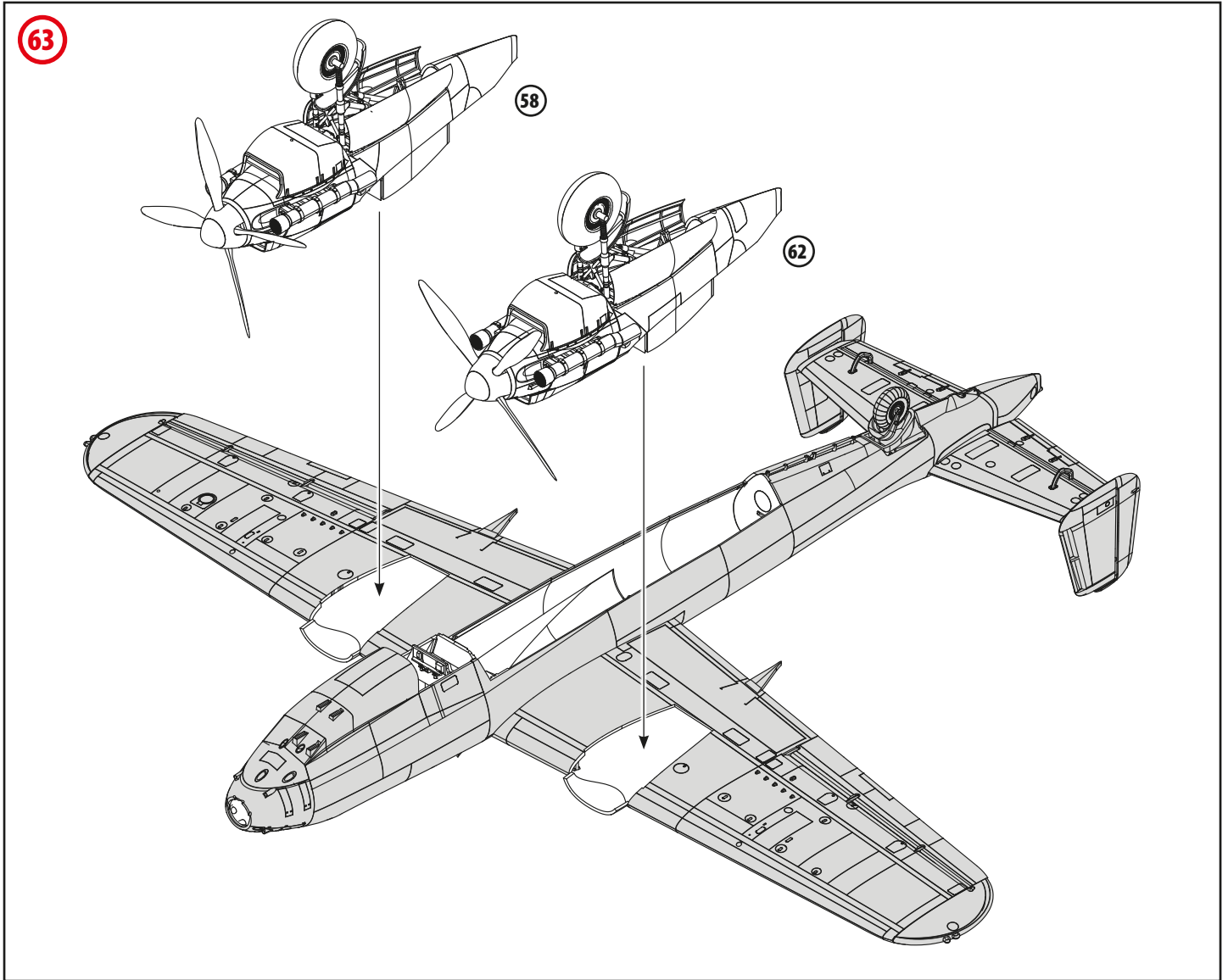

66

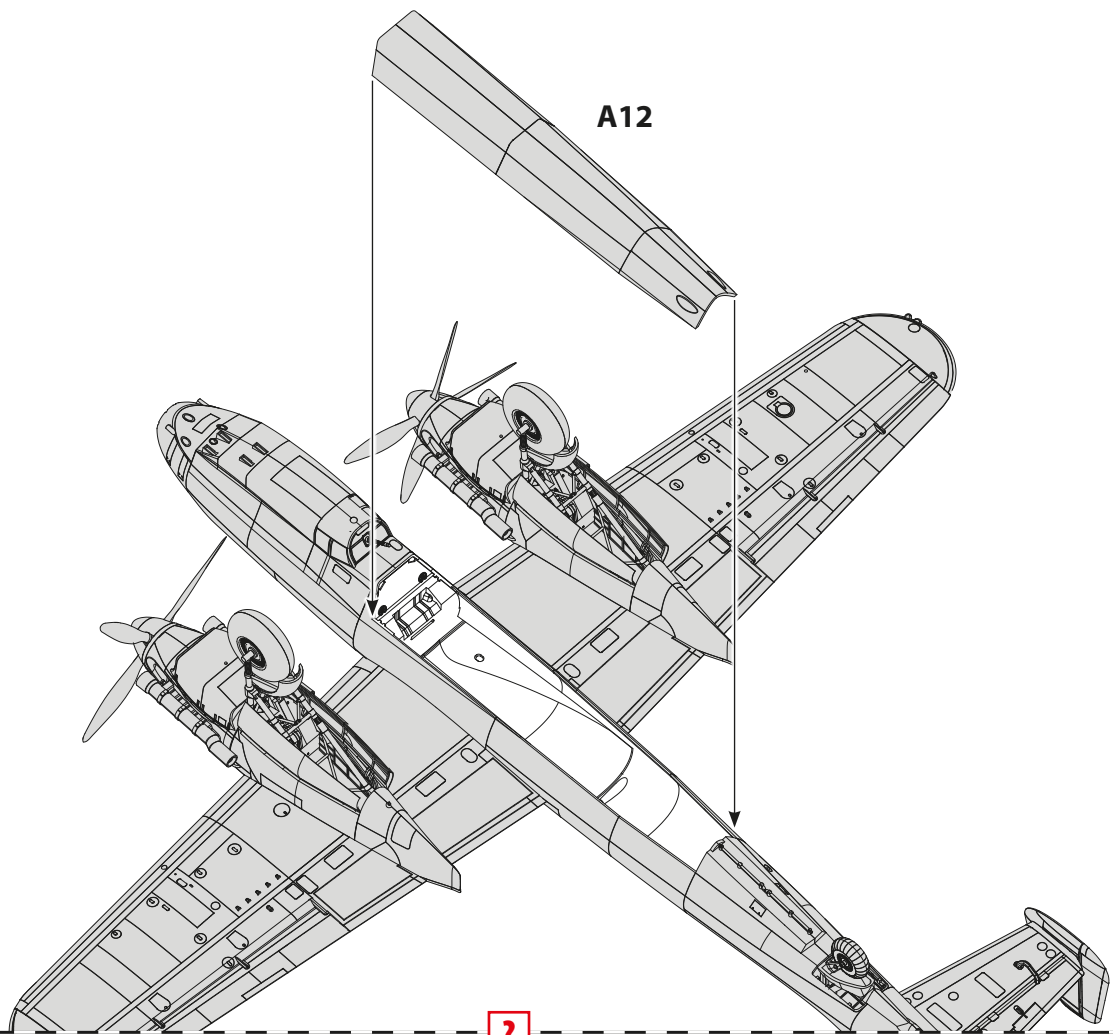

?

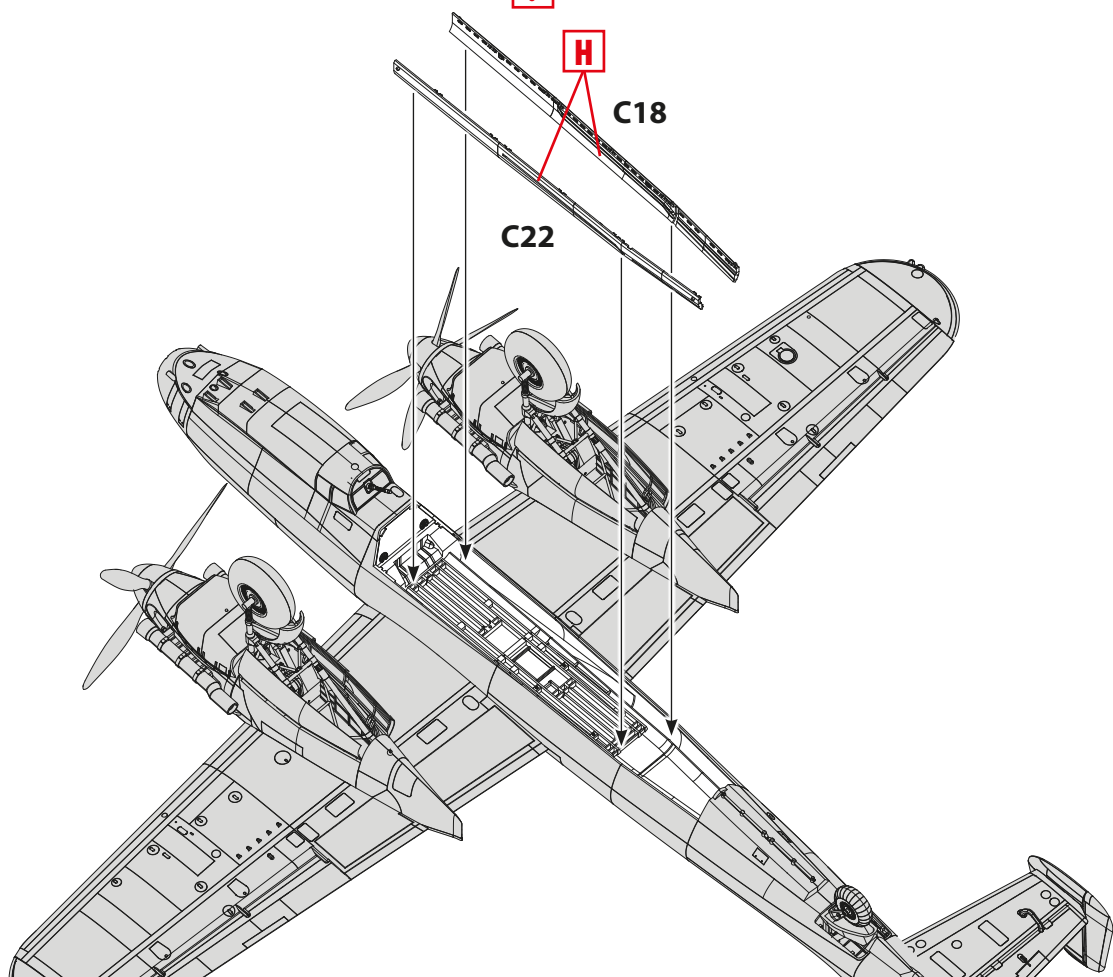

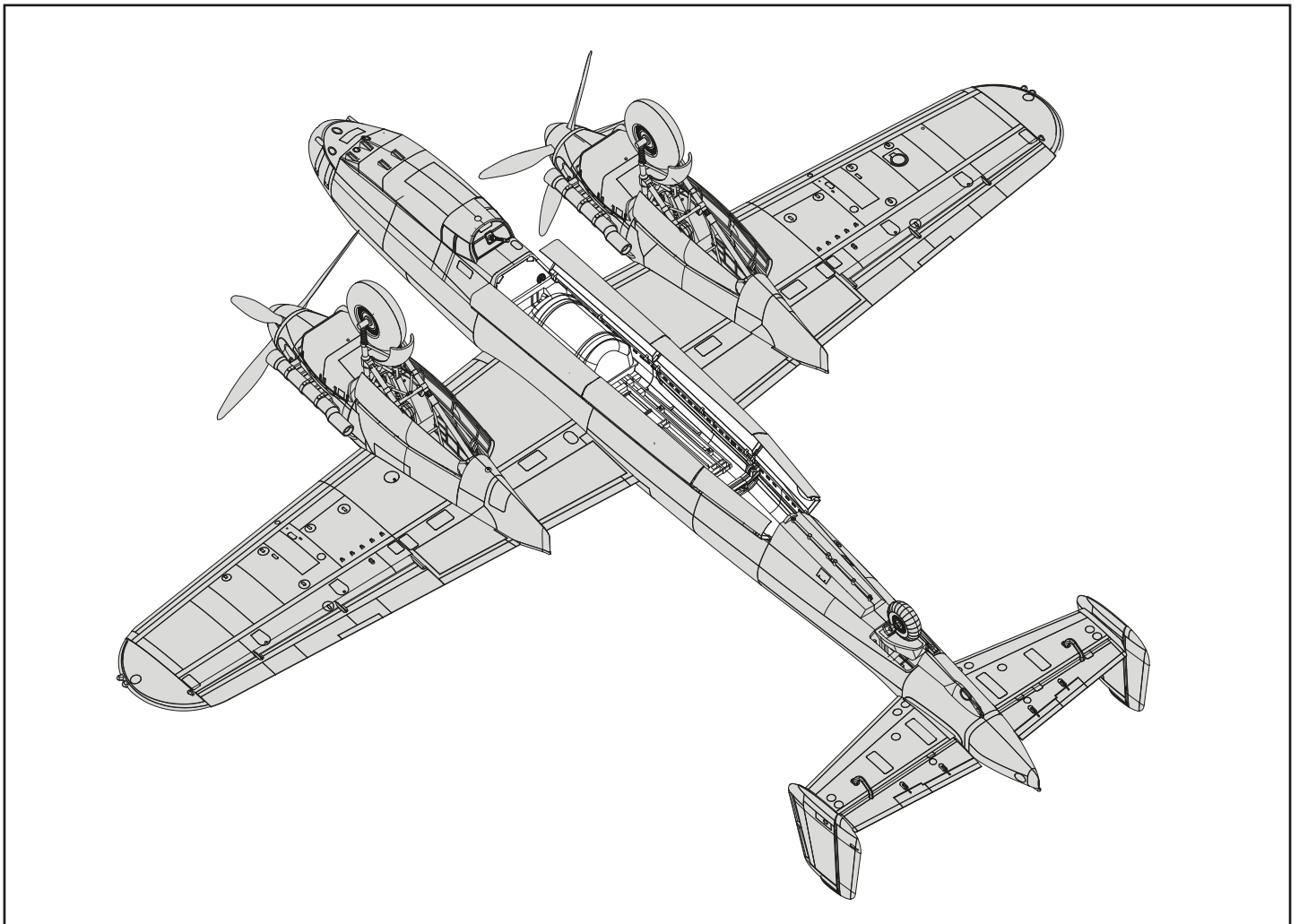
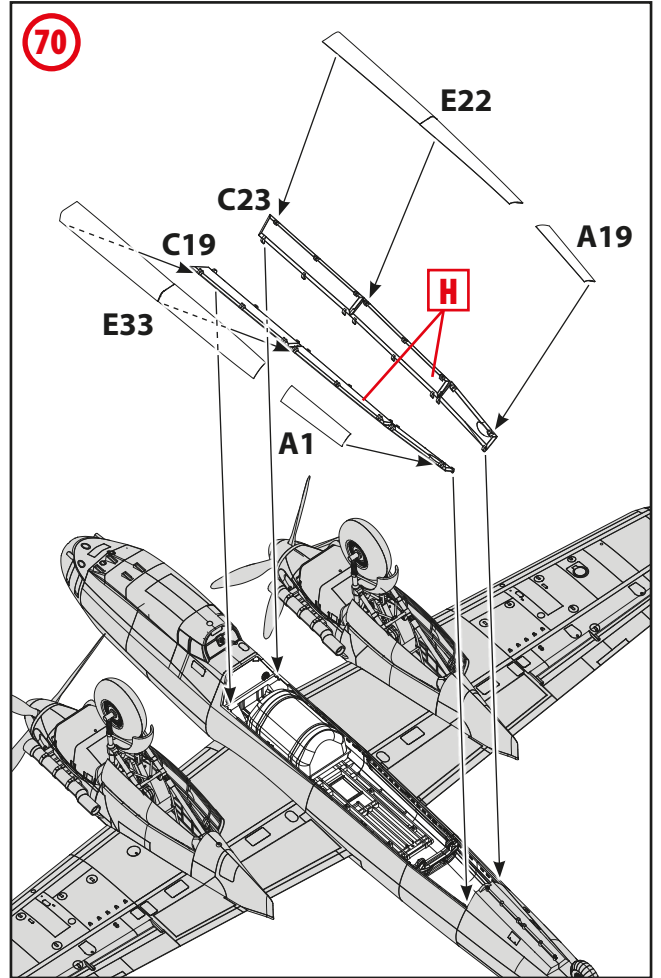
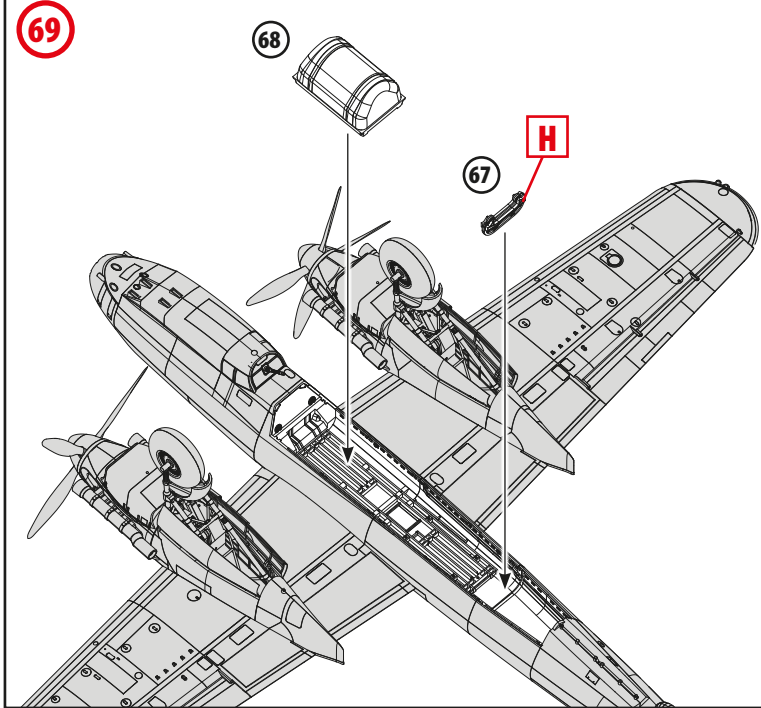
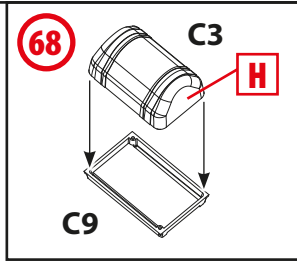
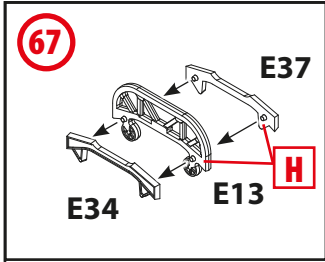

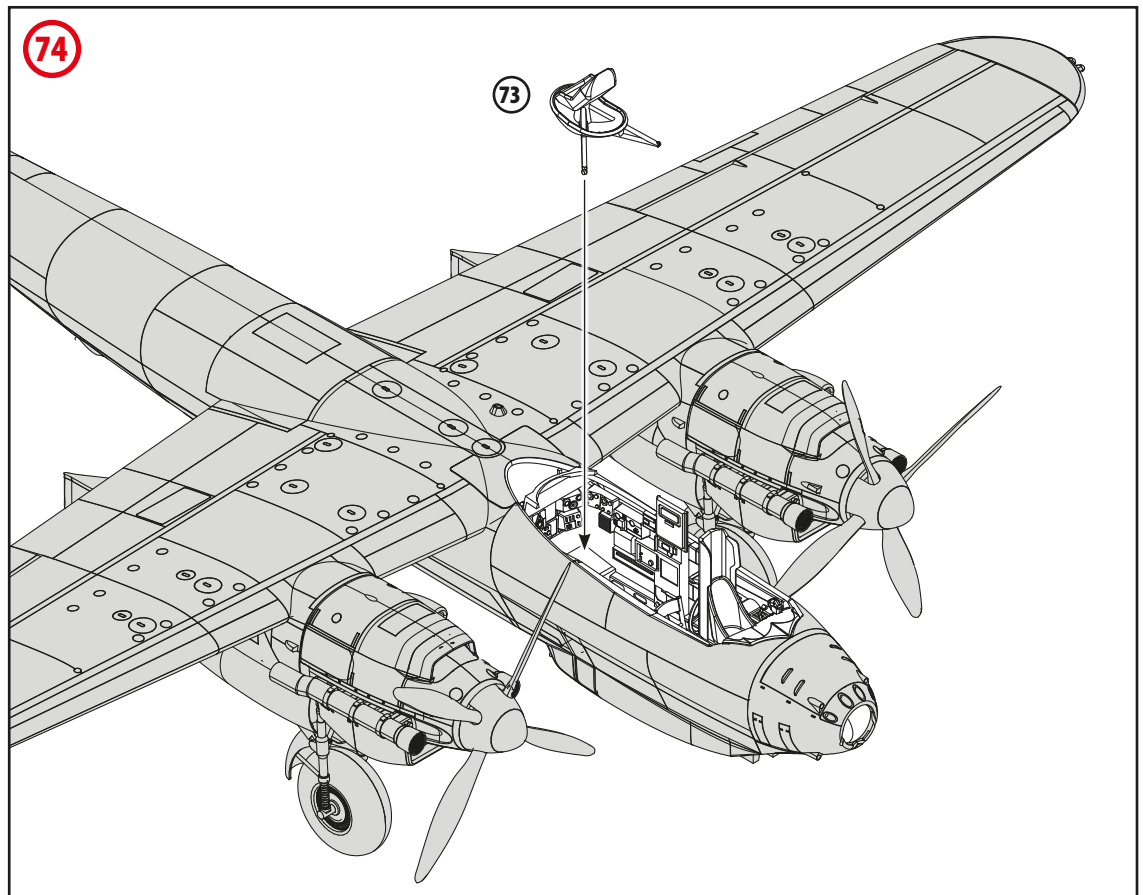
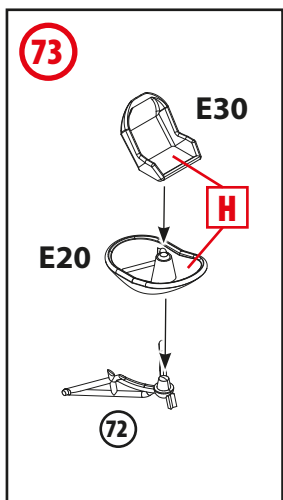
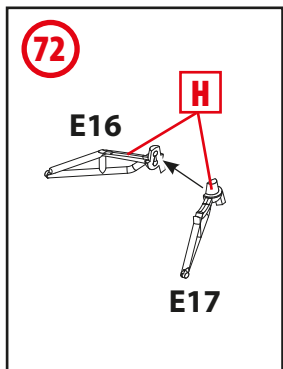
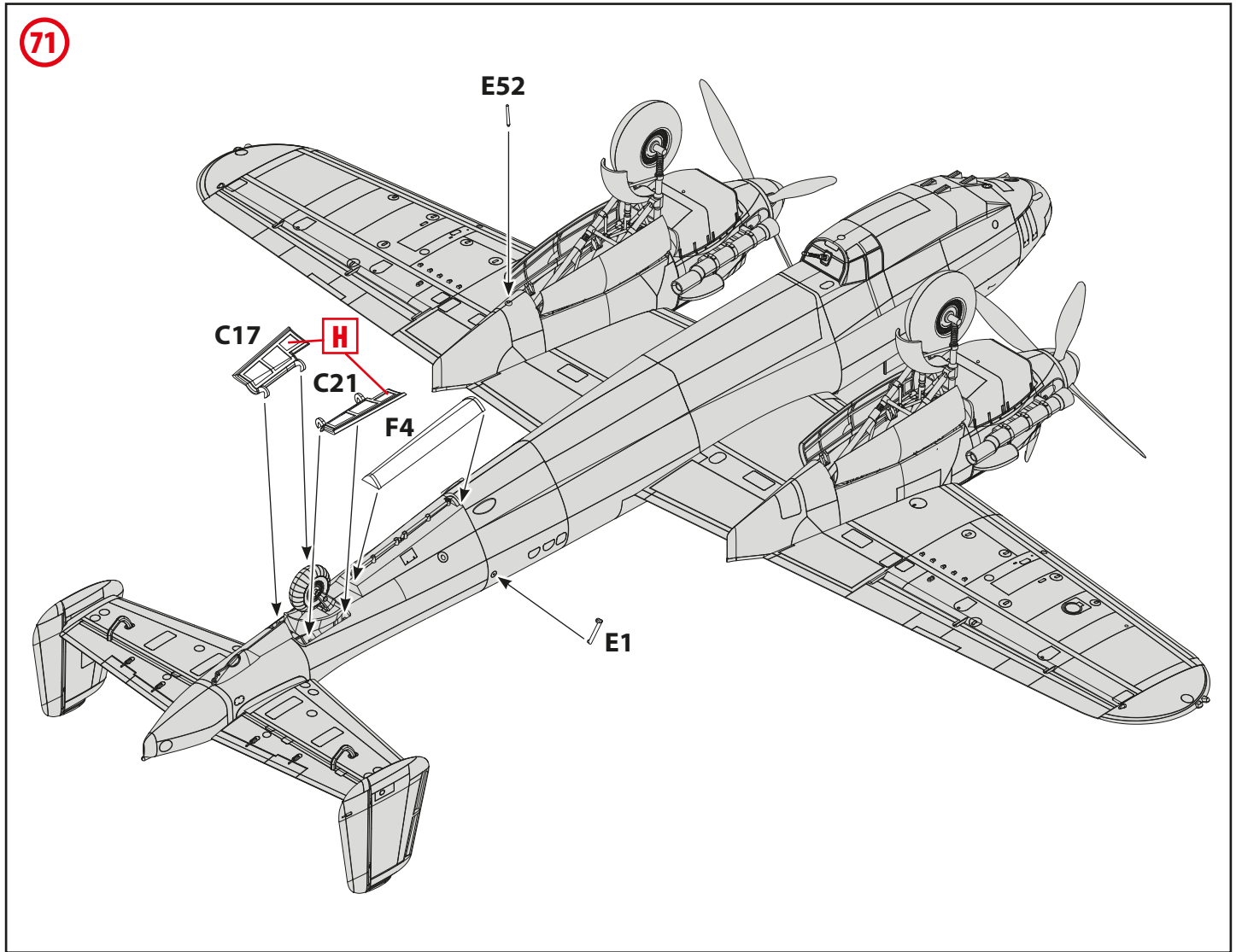

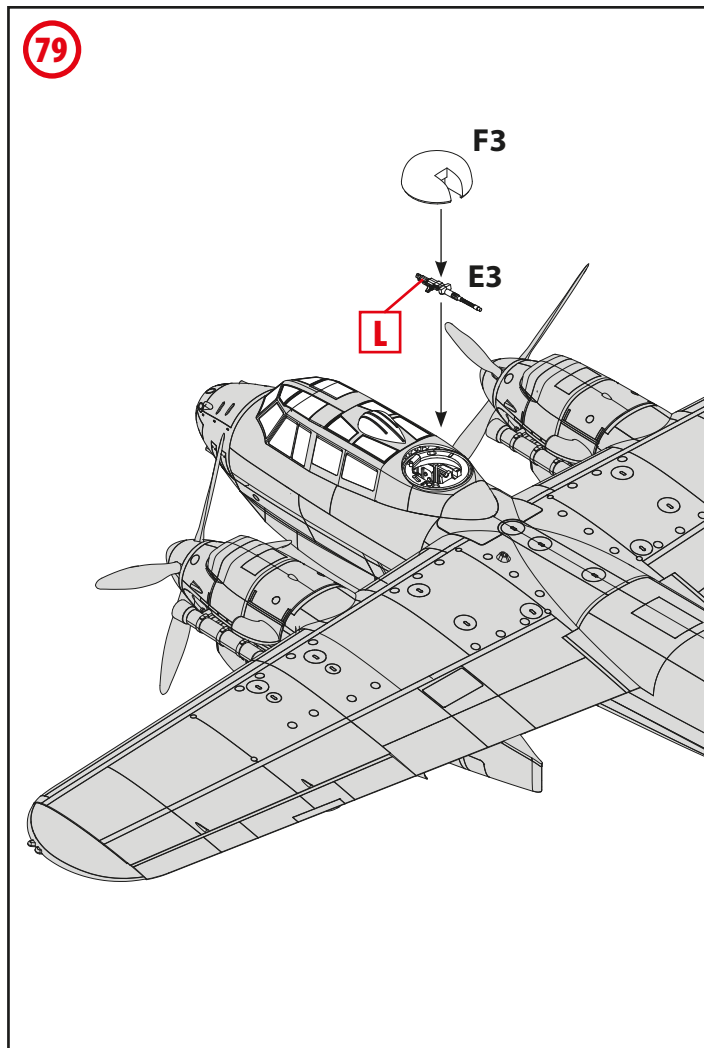
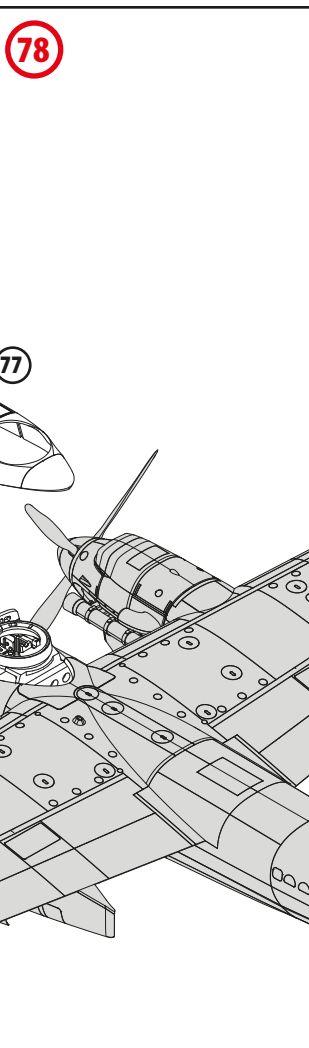
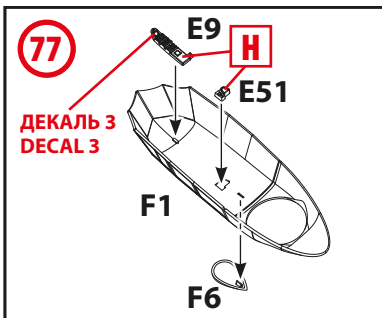
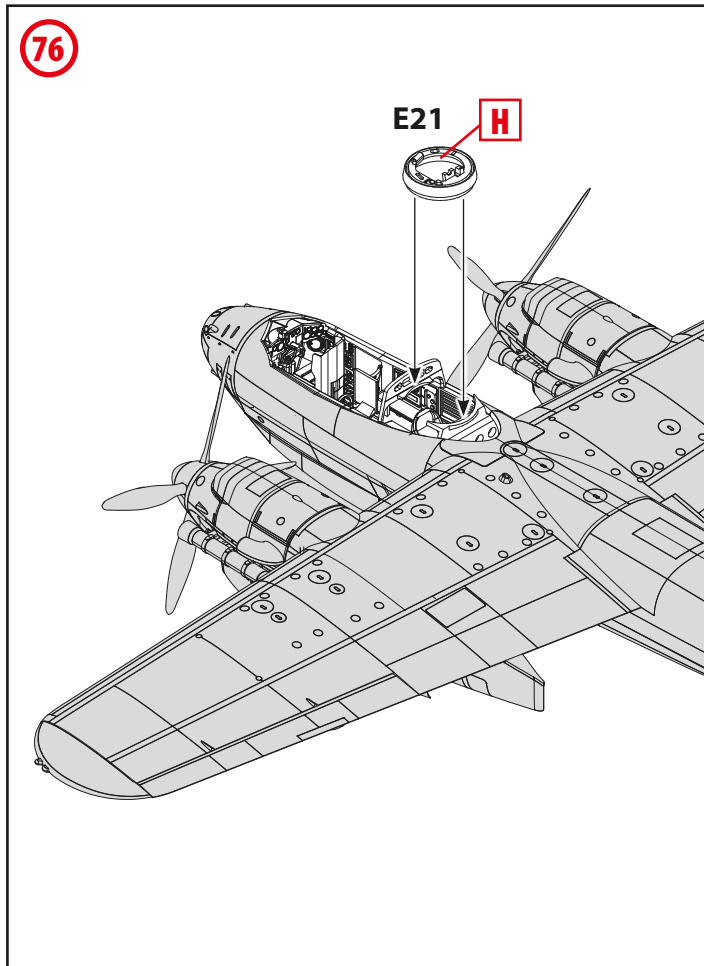
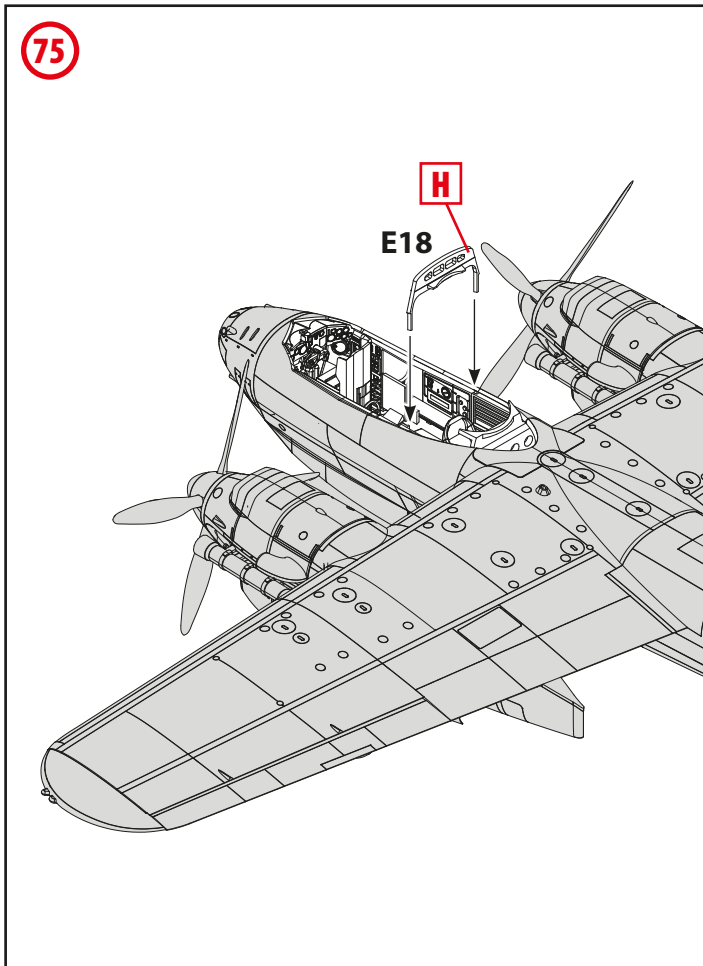

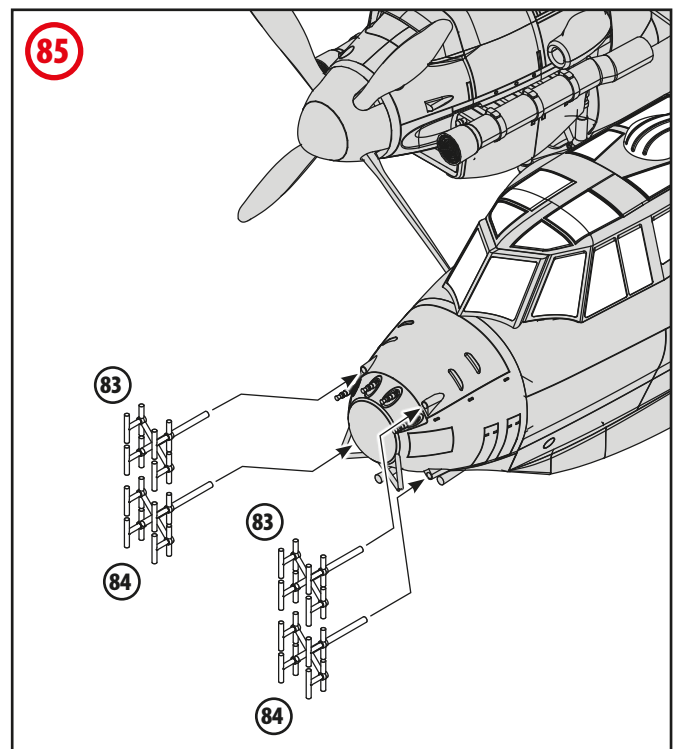
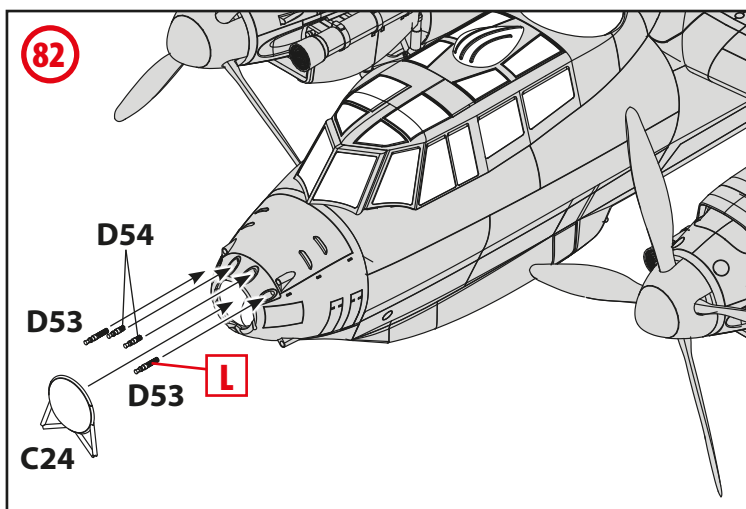
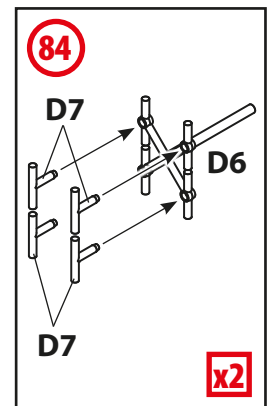
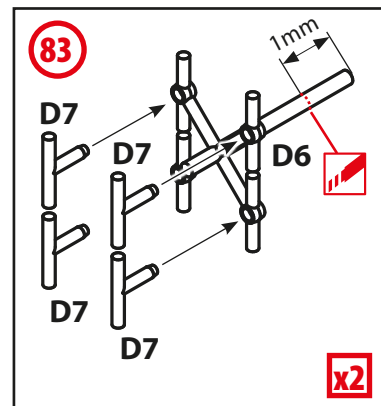
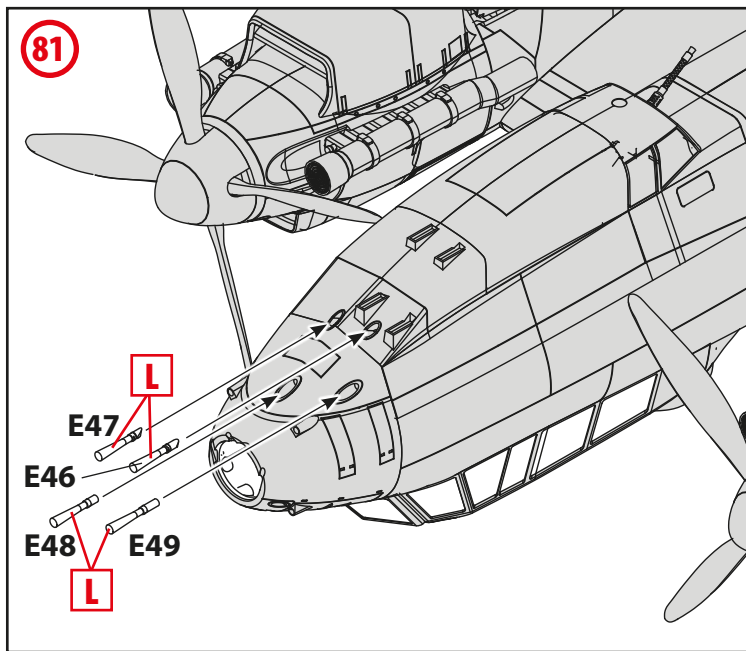
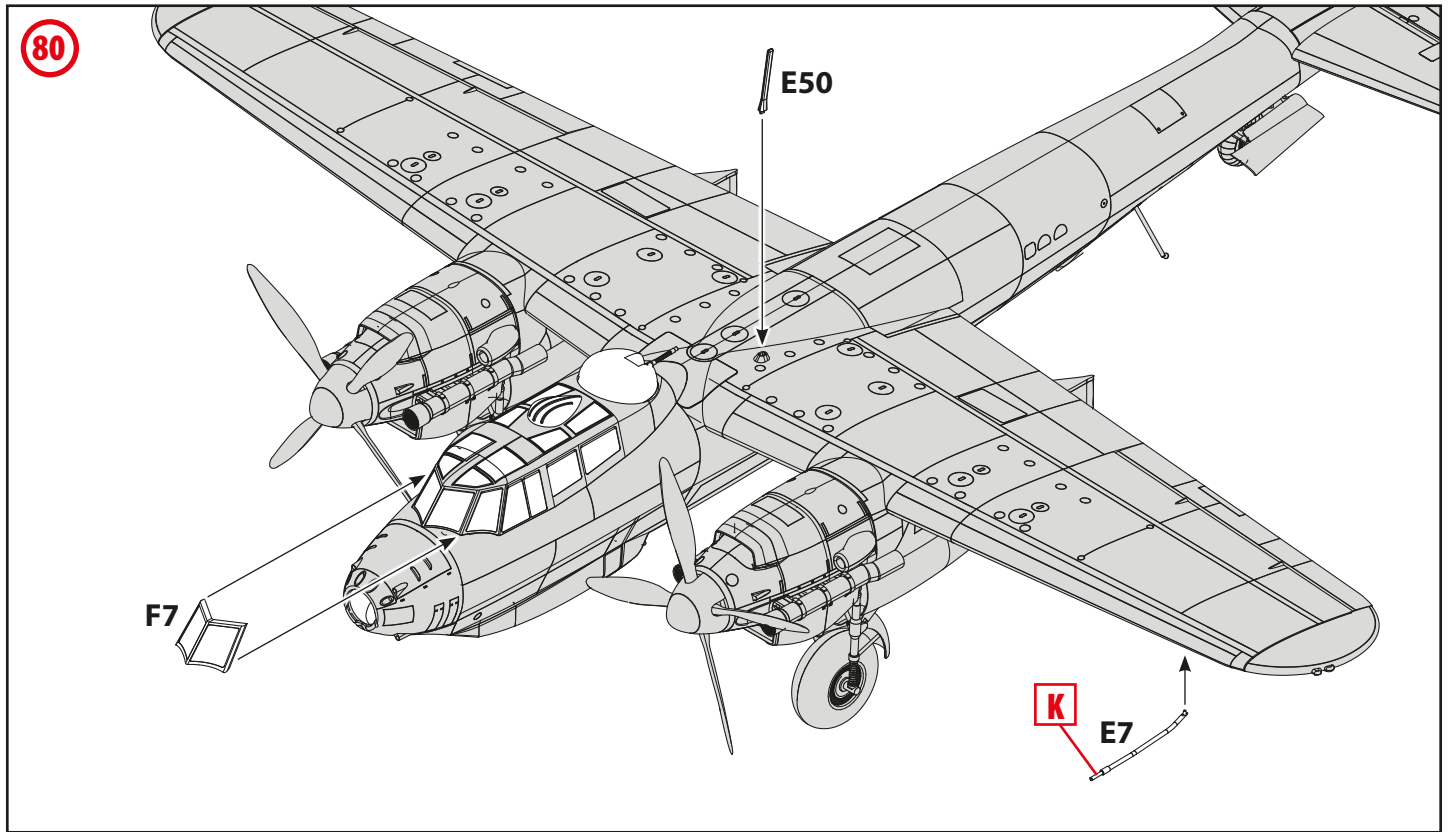

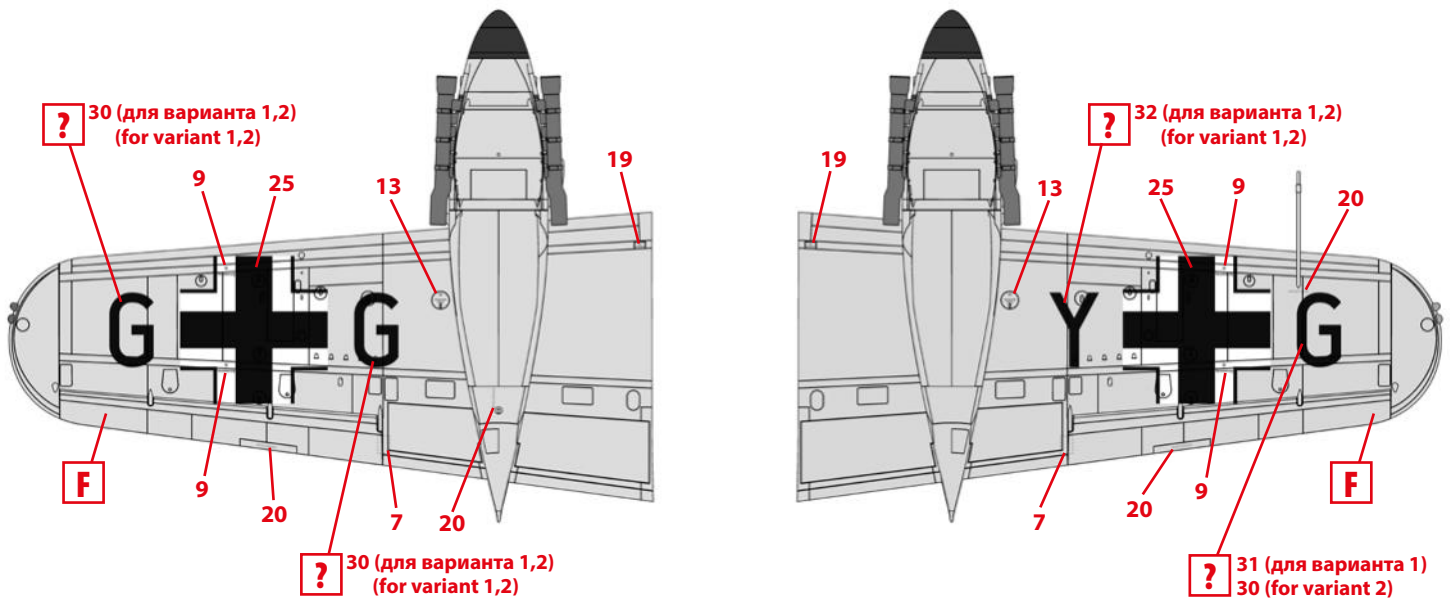
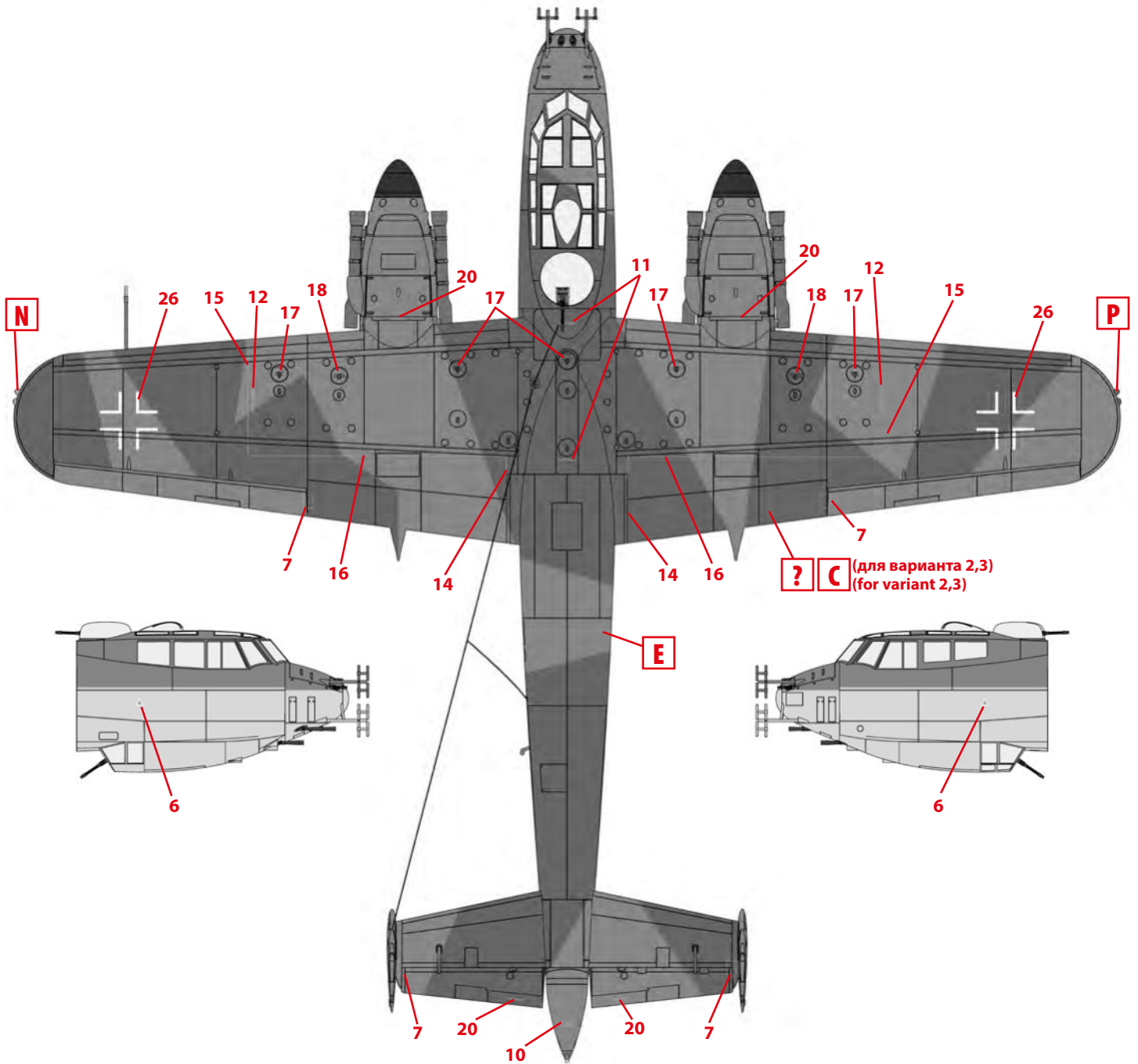

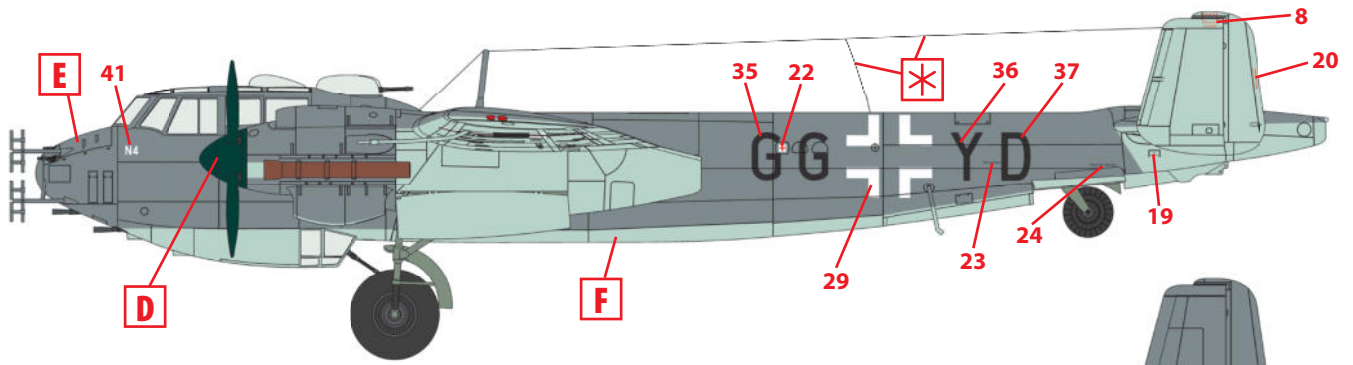

1. Do 217N-1, Рехлин, Германия, весна 1943 г.
Do 217N-1, Rechlin, Germany, Spring 1943



Внутренняя сторона
Inside

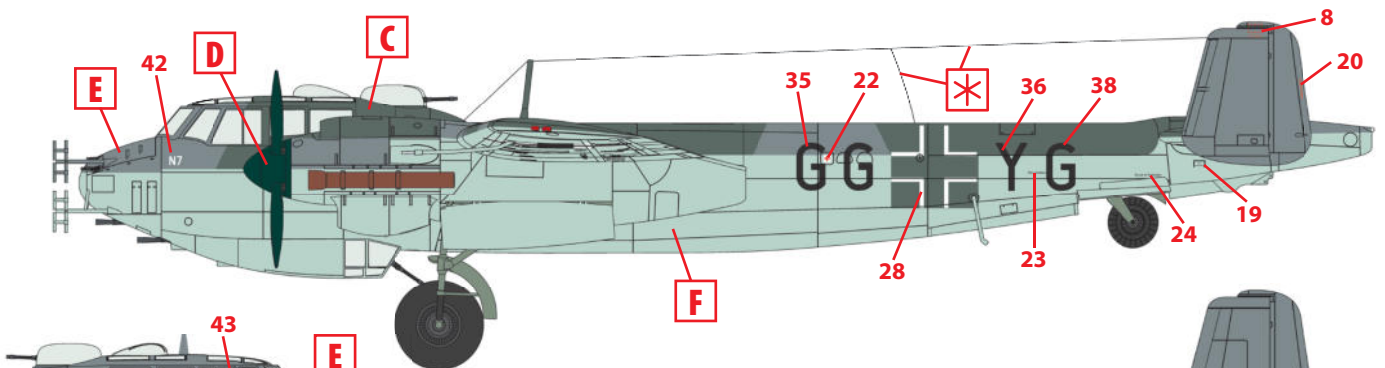
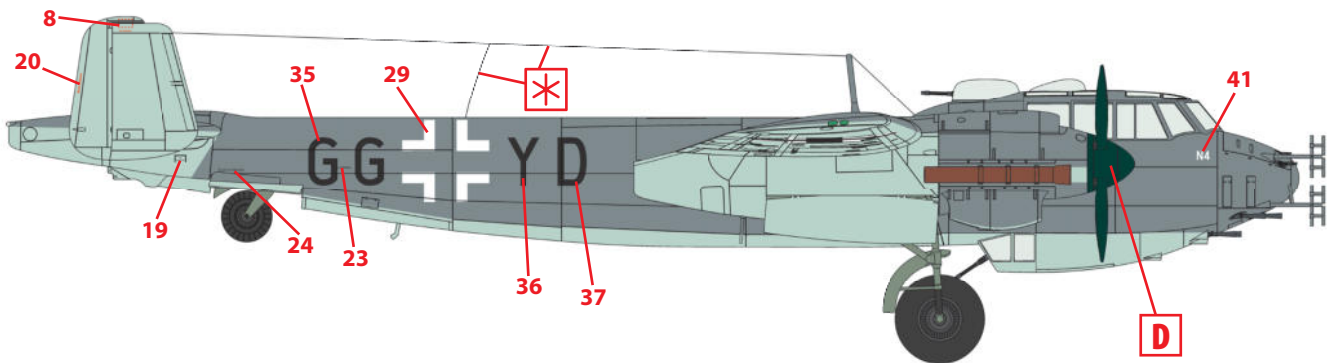

2. Do 217N-1, Рехлин, Германия, лето 1943 г.
Do 217N-1, Rechlin, Germany, Summer 1943



Внутренняя сторона
Inside



Другой вариант окраски
Another painting variant

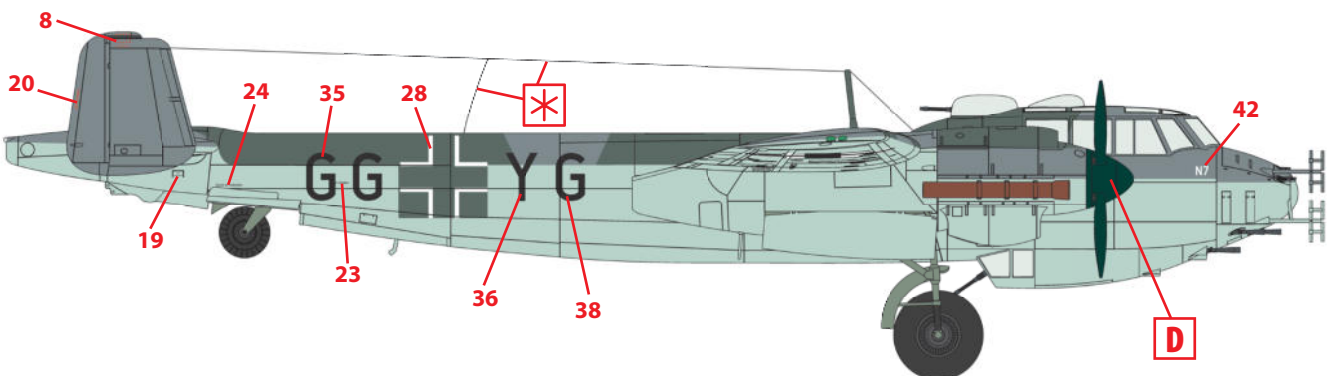

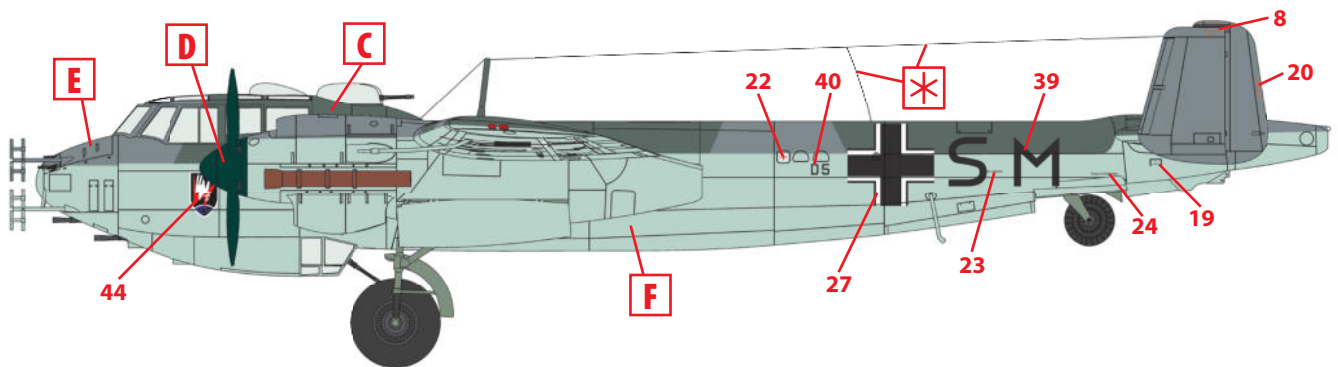

3. Do 217N-1, I./NJG 3, Дания, 1944 г.
Do 217N-1, I./NJG 3, Denmark, 1944

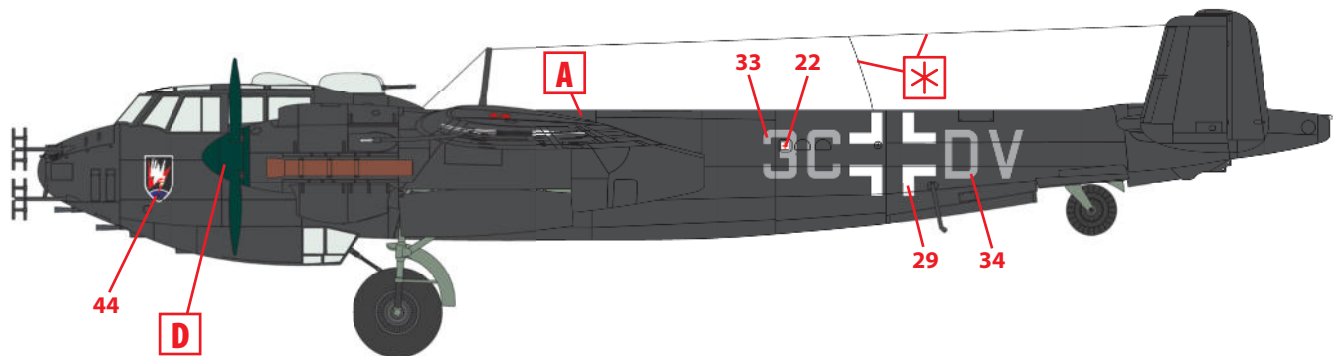
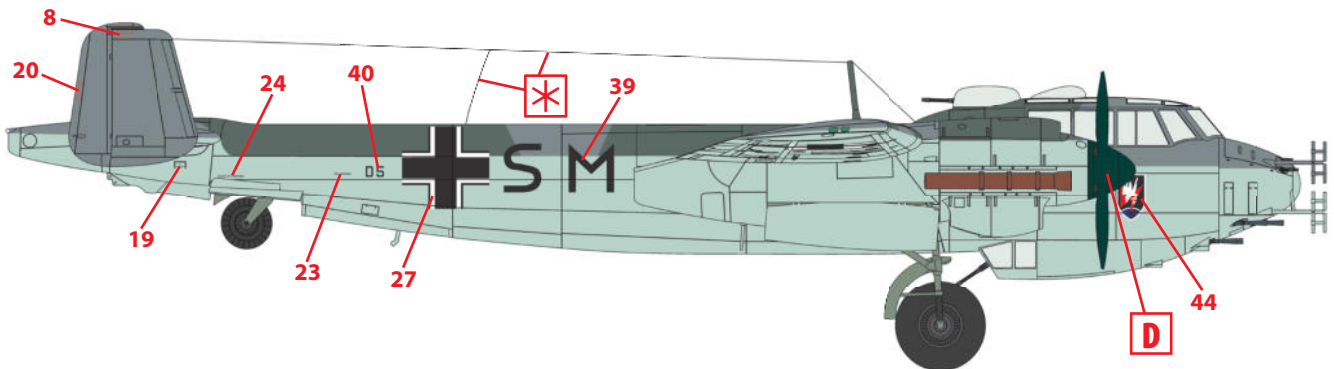

4. Do 217N-1, II./NJG 4, Германия, конец 1943 г.
Do 217N-1, II./NJG 4, Germany, late 1943

