

RC4WD XR2 ULTIMATE MICRO RADIO AND ESC/RECEIVER

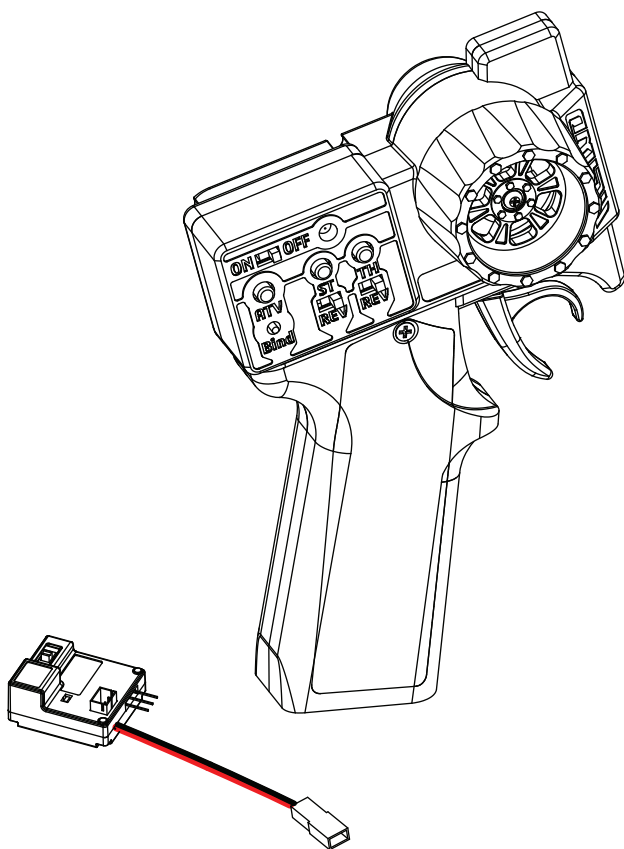

Warranty

RC4WD non-electrical products are warranted to be free of defects in materials and workmanship when new. Our limited warranty does not cover damages due to normal wear and tear, user error of assembly or installation, user modifications, user's failure to perform routine maintenance, addition of aftermarket parts or option parts. This warranty lasts 30 days after arrival for original purchaser.

In the event of a defect under this warranty, RC4WD will, at our discretion, replace the product, provided our inspection indicates that an original defect exists. RC4WD reserves the right to replace any product which is no longer available with a product of comparable value and function. If RC4WD determines the repair is not covered under warranty guidelines, we will contact you to discuss your options. If you have any questions, please contact us via email at support@rc4wd.com.

RC4WD warranties its electronics for 30 days from date of arrival. This covers all electrical items except items that are already noted on the individual product page.

BATTERY CHARGING



1. Only charge batteries that are cool to the touch and are not damaged (swollen, bent, broken or punctured).
2. Connect the charger to USB 2.0 compatible charging block (ie. cell phone charger)
3. Plug the battery's balance port (white plug) into the charger's connector. The LED will be red when it is charging.
4. The charger will have a bright red LED when charging. When charging is complete the LED light will dim and turn off.
5. Always unplug the battery from the charger immediately upon completion of charging.

CAUTION: Overcharging a battery may cause a fire.

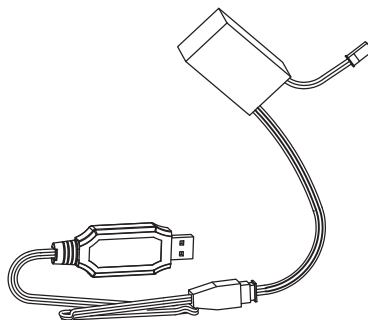

SPECIFICATIONS

Model	RC4WD 2s Lipo Balance Charger
Input	DC5V 1~2A
Output	DC7.4V 800mA

This charger is designed to charge only 7.4V 850mAh 2S LiPo Battery. Do not use this charger with other batteries. RC4WD can not guarantee compatibility with other batteries. Never let children operate unsupervised while charger is in use. Adult supervision is recommended at all times. The charger is for indoor use only. Do not use in case of high humidity conditions or condensation.

Do not attempt to open or modify the charger's case.

Do not let objects or liquids penetrate the charger's cooling vents.

The charger may get hot during use. Use the charger in a well ventilated area, away from people and electrically conductive or inflammable materials.

If the battery has suspicious reactions during the charge or discharge, such as overheating, venting or leaking, immediately disconnect the battery and store it in a safe location, away from people and inflammable materials.



LiPO BATTERY

IMPORTANT: To prevent battery from leaking, overheating or exploding, carefully follow these instructions! Misuse of battery may lead to leakage, heat generation or explosion. Battery may become hot during use. Battery temperature may exceed 25C (77F) even under normal operation and may cause burns or alter the shape of some materials.

SPECIFICATIONS

Rating Voltage	7.4V
Battery Capacity	850mAh
Discharge Rate	25C



- Failure to follow instructions associated with this symbol risks injury or even death!
- If battery liquid enters the eye, immediately flush continuously with clean running water and seek medical treatment. Serious and permanent eye damage may occur.

⚠ WARNING

- Failure to follow instructions associated with this symbol risks injury or even death!
- Avoid battery liquid contact with skin and clothing.
If contact occurs, remove contaminated clothing and wash skin thoroughly with water.

Before Use: Read and understand the battery and charger operating instructions before recharging.

⚠ DANGER

- ONLY use genuine charger unit for recharging brand LiPo batteries.
- ENSURE polarity is correct when plugging a battery into the charger unit.
- NEVER plug a battery directly into household outlets or cigarette lighters in cars!

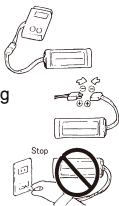

⚠ WARNING

- NEVER place a battery into water.
- IF you experience irregular noise, temperature or any leaking from your battery, stop using it immediately!
- KEEP battery away from exposed flame, high temperatures and humidity.



NOTE: Before any use of this battery, ensure that it is fully charged.

During use: Always monitor a battery while it's charging so you can react to any unexpected problems.

⚠ DANGER

- LiPo batteries are ONLY for use in R/C (radio control) models! Do NOT use them for any other purpose!
- NEVER disassemble or modify a battery!



⚠ WARNING

- Do NOT remove or cut the outer tube from battery!
- DISCONTINUE charging immediately if the charge time has been exceeded, even if the battery is not fully charged.

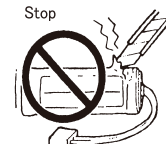

Battery is recyclable. At the end of its useful life, under various national, state or local laws, it may be illegal to dispose of a battery into the municipal waste stream. Check with your local solid waste officials for details in your area for recycling options or proper disposal.

⚠ WARNING

Before using, customers must read information below:

- Use caution when holding the battery. Do not drop or attempt to dismantle the battery or any parts of the battery.
- Do not mix usage of old and new cells or cells of different sizes, different chemistry and/or types in the same battery assembly.
- Do not heat or dispose of battery into fire, water and/or other liquids.
- Do not place the battery into microwave, washing machine and/or drying machine.
- Do not use a damaged battery (such as swollen, deformed, voltage is lower than 0.9V, destroyed, etc.)
- Do not place batteries near heating sources or expose to direct sunlight for long periods. Elevated temperatures may result in reduced battery life cycle.
- Do not short-circuit the battery's positive and negative terminals.
- Do not charge, discharge or store the battery above or below the battery specifications.
- Do not disassemble the battery.
- Before charging battery, ensure polarity is correct.
- Keep battery far away from easily flammable objects and children while charging.
- Do not charge when battery is hot to the touch. Allow battery to cool before recharging.
- Never leave batteries unattended while charging.
- Do not leave battery installed in your model while not in use. Do not charge the battery while installed in models.

XR2 Ultimate Micro Radio and ESC/Receiver

The following is an overview of the various functions and adjustments found on XR2 Ultimate Micro radio system for RC4WD models. It is important to read and understand about all of these functions and adjustments before driving.

1. Transmitter Functions

Description	Specifications
Steering Wheel	Controls direction (Left / Right)
2.4 Antenna	Transmits signal to the model
Throttle Trigger	Controls speed (Forward / Brake / Backward)
TH. Trim Dial	Adjusts the model to stop when throttle trigger is at stop position
LED indicator	Binding indicator and Low Battery indicator
ST. Trim Dial	Adjusts the model to run straight when steering wheel is at center position
Power ON / OFF	Power ON / OFF the transmitter
ATV	Adjusts the maximum steering angle when model turns Left / Right
Bind	Allows TX to pair with RX
ST Reverse Switch	Reverse direction when operating steering wheel
TH Reverse Switch	Reverse direction when operating throttle trigger
Battery Compartment Tray	Contains batteries for powering the transmitter

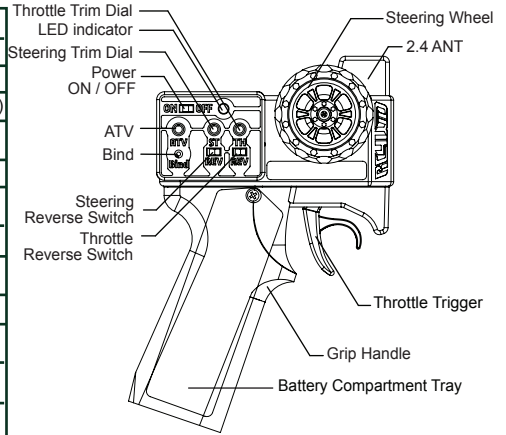

* User should practice the throttle and steering approach for different cornering at different speeds or road surfaces.

2. Battery Installation

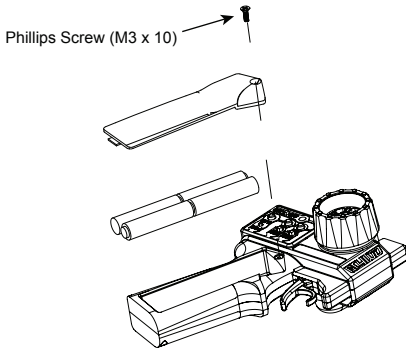

- (1) Use a Phillips screwdriver to remove the screw at the handle and remove the battery compartment cover.
- (2) Install the 4x 1.5V AA batteries with correct polarity as marked on the battery compartment.
- (3) Reinstall the battery compartment cover.

Warning: Never disassemble batteries or place the batteries in a fire or chemical bath.

Battery Disposal: Observe your local regulations for proper disposal of batteries.

3. ESC/Receiver Connections

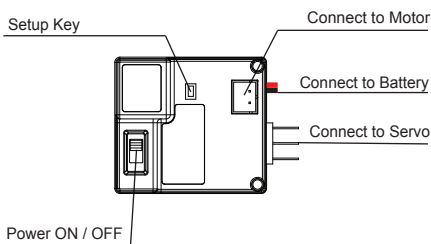

Type	Micro RX/ESC	
Binding	LED Flashing Quickly	
Normal Operation	Lipo	LED Solid On
	NiMH	LED Flashing Slowly
When no signal is received at RX / ESC	Repeating blink two times quickly	

* The LED will remain solid during operation when the battery type is LiPo and RF signal is received. If user wants to select NiMH battery, hold the key for 5+ seconds, the RX/ESC will change to the other battery type. For NiMH, the LED will continually flash once RF signal is received.

XR2 Ultimate Micro ESC/Receiver

1. ESC/Receiver Features

Type	2.4GHz RX with Crawler ESC
Servo Port	Standard 3 Pin Servo Port
BEC For Servo	5V,1A
Battery	7.2V NiMH or 2S LiPo, JST connector (Use setup key to select battery type)

2. ESC/Receiver

Status	LED	Remark
TX Off	LED Off: If after 4 sec with no TX detected, it will flash 2 times repeatedly to indicate loss of signal.	
Normal Operation: LiPo Mode	LED Solid On	To select battery type, See section 3
Normal Operation: NiMH Mode	LED Flashing Quickly	To select battery type, See section 3

3. Selecting Battery Type

During normal operation, hold the key for 5+ seconds until LED change status. Now battery type is changed and saved in the memory.

4. Electrical Specifications

Description	Specifications
Low Voltage Cut-off (NiMH)	4V (Motor will stop once battery voltage below this value)
Low Voltage Cut-off (LiPo)	6.6V (Motor will stop once battery voltage below this value)
Max Battery Voltage	9V
Max Continuous Current	3.5A
Max Peak Current	6A
Thermal Protection	110°C
Stall Protection	By current limit – 3A
BEC	5V, 1A with Thermal and Over Current Protection

XR2 Ultimate Micro Radio

1. Transmitter Features

Type	2.4GHz, Frequency Hopping, FHSS
2 Channel System	Programmable Steering End-points by Setup Key
	Programmable Throttle End-points by Setup Key
	Adjustable Steering Trim
	Adjustable Throttle Trim
	Dual Rate Steering
	Low Battery Indicator LED

2. Pairing to TX

- 1 Power off the TX

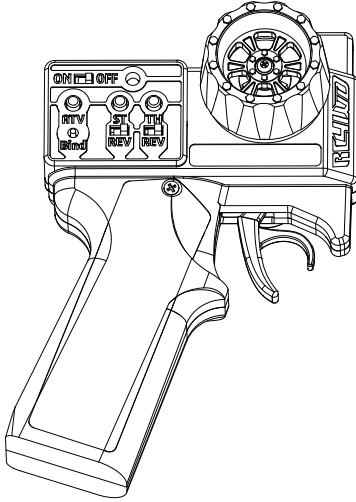

- 2 Press and hold the program button of the RX/ESC and turn on RX/ESC, the LED will flash slowly.

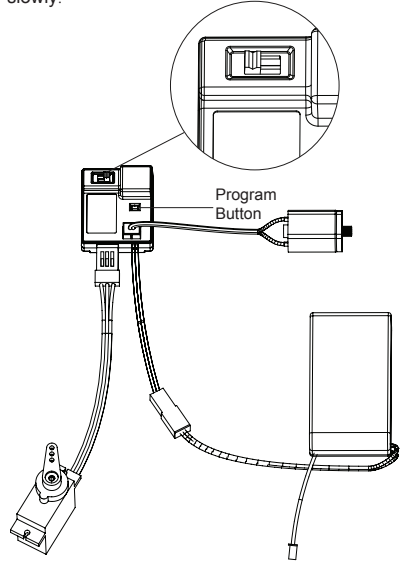

- 3 Hold the Bind button of TX and then power on TX. TX LED will flash when binding starts.

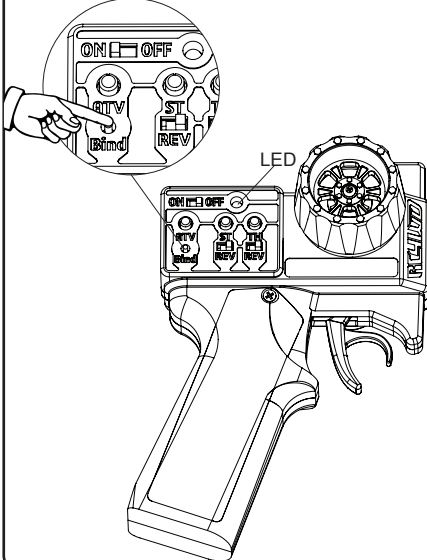

- 4 When the RX LED Solid On, this means RX has paired to TX successfully. If TX LED stops flashing and RX is not bound, move closer and start over at step 1.

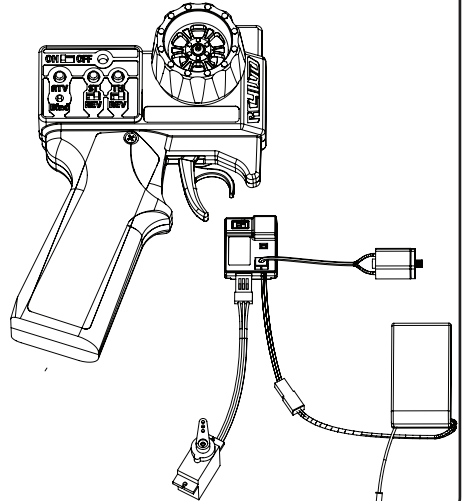

3. Setup Your Radio

a) Reverse Switches, Trim and ATV Knob

- 1 If the truck turns the wrong direction when driving, you can reverse the direction with the reverse switch. The same principle can be applied to forward and reverse.

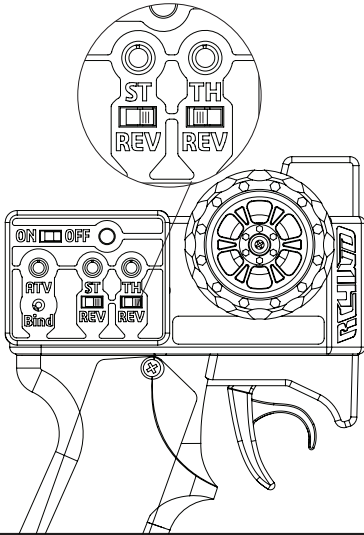

- 2 Use the steering trim to make minor adjustments to keep truck going in a straight line when not steering.

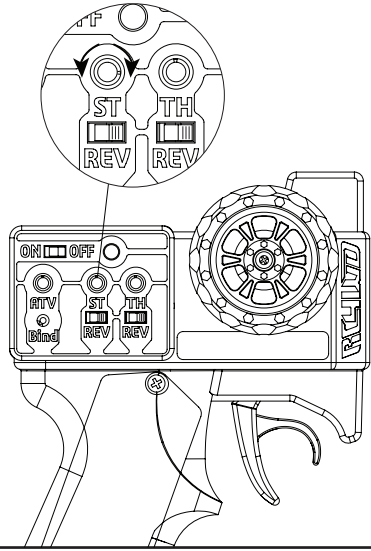

- 3 Use throttle trim to adjust if truck does not stop when not using the throttle.

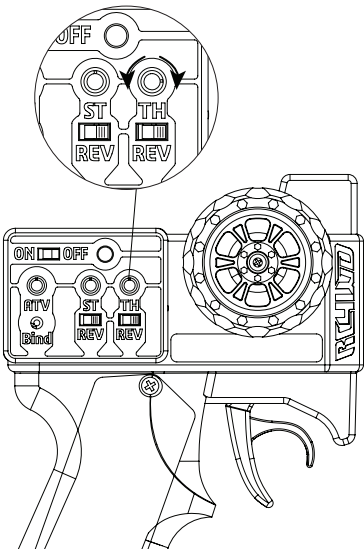

- 4 Use the ATV Knob to adjust the steering endpoints. This can be used to make the truck steer more or less sharp.

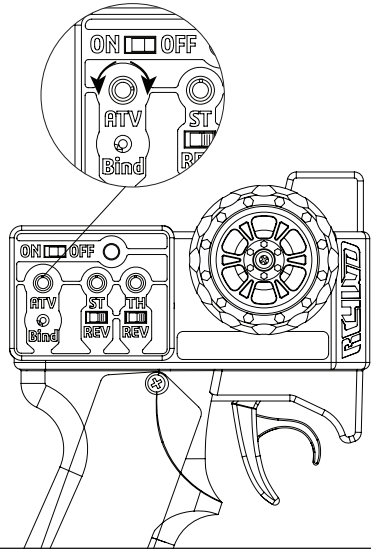

b) Programming the End-points

To set the Right End-point of Steering

- 1 Turn on TX and RX.

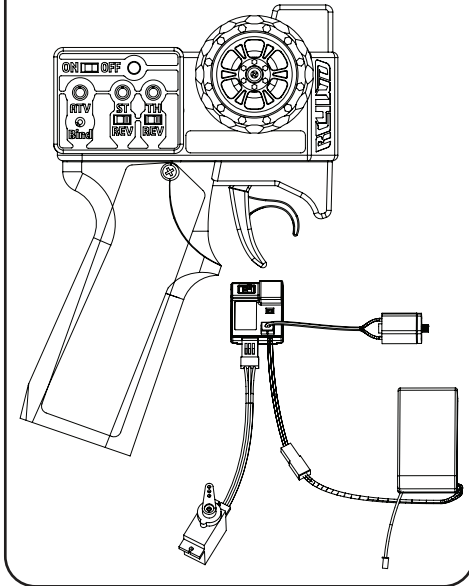

- 2 Hold the steering wheel at right-most position and then hold the setup key for 10+ seconds until LED flashes.

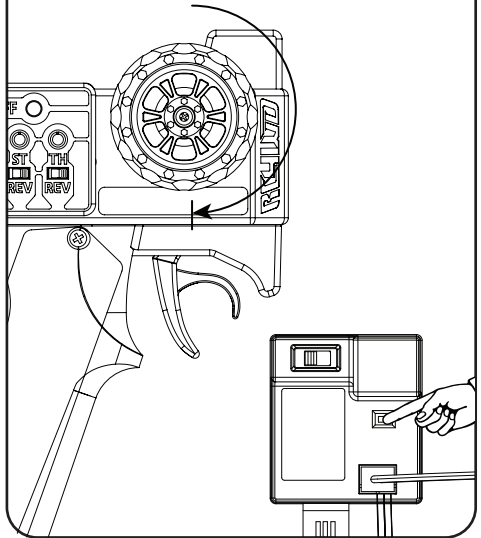

- 3 Move the steering wheel until the front wheel is at the right-most position. Then hold the steering wheel at this position and press the setup key to save this End-point.

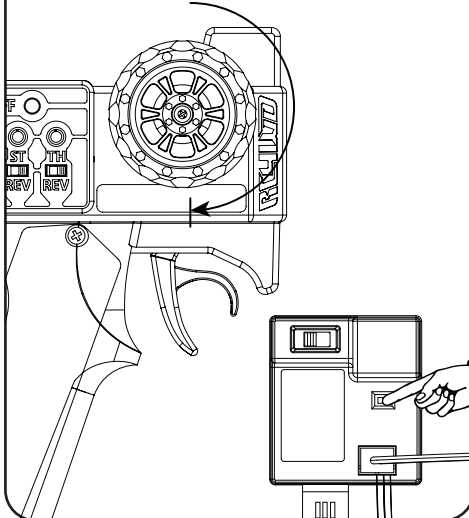

- 4 The LED will blink 4 times and then return the TX back to normal operation.

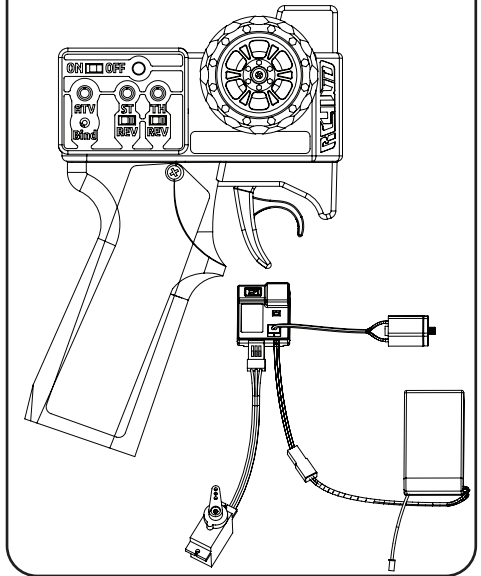

To set the Left End-point of Steering

- 1 Similar to above, only difference is hold the steering at left-most position and then hold the setup key for 10+ seconds.

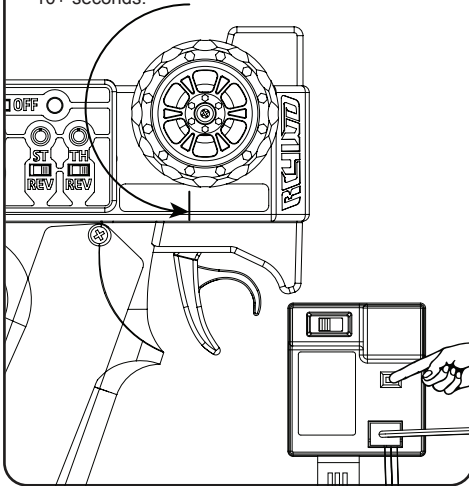

Throttle End-points Programming

- 1 Similar to steering end-point programming, hold the throttle at forward-most position to set forward end-point, (Reverse-most position to set reverse end-point) hold the setup key for 10+ seconds.

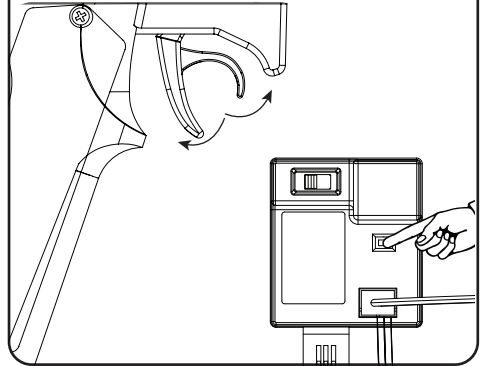

4. Low Battery Indicator

- 1 During normal operation, the LED should be solid ON.

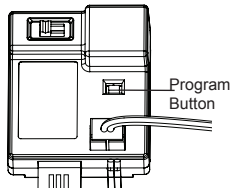

- 2 Once battery gets too low, the LED will begin flashing very slowly to indicate battery is low. You should replace with a new battery as soon as possible.

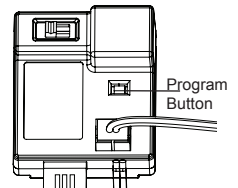

Instructions for Disposal of WEEE by Users in the European Union

These products must never be thrown away with other waste. Thus, the users are responsible for disposing the used batteries by submitting them to designated collection stations specific for recycling electronic and electric items. Disposing of the used batteries in this way is helpful in conserving natural resources and promotes human health while protecting the environment. For more information about used battery disposal and recycling, please contact your local city office, your disposal service, or where you purchased the products.

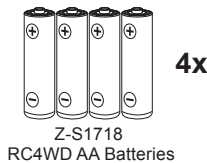

Safety Precautions

**THIS MODEL IS ONLY SUITABLE FOR PEOPLE 14 YEARS OLD AND UP.
THIS RADIO CONTROL MODEL IS NOT A TOY.**

It is recommended that beginners seek advice from an experienced person in order to assemble the model or parts correctly.

* During assembly: Keep out of reach of children. Parts are small and may be hazardous to small children.

Use precaution while operating this model. User is fully responsible for the model's assembly and safe operation.



Introduction

This is an advanced hobby grade product. It must be operated with caution and common sense. Basic mechanical aptitude is required to operate this model: Failure to operate this product in a safe and responsible manner could result in injury, damage the product or other properties. This product is not intended for use by children without direct adult supervision. The product manual contains instructions for safe operation and maintenance. It is essential to read and follow all the instructions and warnings in the manual prior to assembly, setup and use, in order to operate correctly and avoid damage or injury.

Safety, Precautions and Warnings

As the user of this product, you are solely responsible for operating it in a manner that does not endanger yourself and others or result in damage to the product or the property of others.

This model is controlled by a radio signal that is subject to interference from many sources outside your control. This interference can cause momentary loss of control so it is necessary to always keep a safe distance in all directions around your model, as this will help to avoid collisions or injury.

- Always operate your model in an open area away from cars, traffic or people.
- Avoid operating your model on the street where injury or damage can occur.
- Never operate the model on a busy street or populated areas for any reason.
- Never operate your model with low transmitter batteries.
- Carefully follow the directions, warnings for this product and any optional support equipments (chargers, rechargeable battery packs, etc.) that you use.
- Keep all chemicals, small parts and anything electrical out of the reach of children.
- Moisture causes damage to electronics. Avoid water exposure to all equipment not specifically designed and protected for this purpose.

CE Compliance Information for The European Union

The associated regulatory agencies of the following countries recognize the noted certifications for this product as authorized for sale and use.

UK	DE	DK	BG	SE	CZ	ES	NL	SK	HU	RO	FR	PT
FI	EE	LV	LT	PL	AT	CY	SI	GR	MT	IT	IE	LU

FCC ID: 2AOMDCTX01

FCC Statement:

Manufacturer name: RC4WD Inc.
Company address: 720 N. Gateway St. Visalia, CA 93291
Contact information: support@rc4wd.com
Applicable environment: Toy
Frequency range: 2.4GHz
Transmit power: Below 100mW

This equipment has been tested and found to comply with the limits for a Class B digital device, pursuant to part 15 of the FCC Rules. These limits are designed to provide reasonable protection against harmful interference in a residential installation. This equipment generates, uses and can radiate radio frequency energy and, if not installed and used in accordance with the instructions, may cause harmful interference to radio communications. However, there is no guarantee that interference will not occur in a particular installation. If this equipment does cause harmful interference to radio or television reception, which can be determined by turning the equipment off and on, the user is encouraged to try to correct the interference by one or more of the following measures:

- Reorient or relocate the receiving antenna.
- Increase the separation between the equipment and receiver.
- Connect the equipment to an outlet on a circuit different from that to which the receiver is connected.

This device complies with part 15 of the FCC rules. Operation is subject to the following two conditions: (1) This device may not cause harmful interference, and (2) this device must accept any interference received, including interference that may cause undesired operation.

NOTE: Modifications to this product will void the user's authority to operate this equipment.

RF Exposure Warning:

This equipment complies with FCC radiation exposure limits set forth for an uncontrolled environment. And should be operated with minimum distance of 20 cm between the antenna & your body.

